

**Photovoltaic Facades: Key to the Concept of Zero Energy
Buildings**

صفر الطاقة المباني مفهوم مفتاح: الضوئية واجهات

by

MATHEW GEORGE KAMPADAM

**Dissertation submitted in fulfilment
of the requirements for the degree of
MSc SUSTAINABLE DESIGN OF BUILT ENVIRONMENT**

at

The British University in Dubai

September 2021

DECLARATION

I warrant that the content of this research is the direct result of my work and that any use made in it of published or unpublished copyright material falls within limits permitted by international copyright conventions.

I understand that a copy of my research will be deposited in the University Library for permanent retention.

I now agree that the material mentioned above for which I am the author and copyright holder may be copied and distributed by The British University in Dubai for research, private study, or education and that The British University in Dubai may recover from purchasers the costs incurred in such copying and distribution, where appropriate.

I understand that The British University in Dubai may make a digital copy available in the institutional repository.

I understand that I may apply to the University to retain the right to withhold or to restrict access to my thesis for a period which shall not normally exceed four calendar years from the congregation at which the degree is conferred, the length of the period to be specified in the application, together with the precise reasons for making that application.

Signature of the student

COPYRIGHT AND INFORMATION TO USERS

The author whose copyright is declared on the title page of the work has granted to the British University in Dubai the right to lend his/her research work to users of its library and to make partial or single copies for educational and research use.

The author has also granted permission to the University to keep or make a digital copy for similar use and for the purpose of preservation of the work digitally.

Multiple copying of this work for scholarly purposes may be granted by either the author, the Registrar or the Dean of Education only.

Copying for financial gain shall only be allowed with the author's express permission.

Any use of this work in whole or in part shall respect the moral rights of the author to be acknowledged and to reflect in good faith and without detriment the meaning of the content, and the original authorship.

ABSTRACT

Buildings around the globe consume almost 40 % of energy, and building operations are based on non-renewable sources of energy, e.g., ventilation, air conditioning, electricity, heating, which contributes to over 33% of greenhouse gases. To sustain our future generations from the adverse effects of greenhouse gases, buildings hold a major potential. If a building greatly reduces energy needs through efficiency gains such that the balance of energy needs can be supplied with renewable technologies-thus, that building can be termed as zero energy building.

To achieve a zero building concept, the building should be designed to reduce energy consumption to a minimum. The building should be able to produce energy on itself. To achieve the aim of this concept, building envelope's, facades are the ultimate potential key in an envelope which will lead to minimum energy consumption and also energy production with the help of photovoltaic facades

Building-integrated Photovoltaic facades are an important solution proposal. However, its implementation is accompanied by significant challenges in terms of the complexity of processes and technologies involved and the adaptability of these solutions to different geographical areas with particular climatic conditions.

This research aims to assess the viability of the implementation of photovoltaic facades in commercial and residential projects. The viability will be studied in terms of the overall savings in the power usage, economic feasibility, and detailed techno-commercial study and comparison with the conventional façade methods.

The objective of the study of study are:

- Energy production details.
- Impacts on the cost in comparison with electrical power consumption.
- Possible aesthetics of the photovoltaic facades.
- Research & developments in building design for the maximum application of the photovoltaic facades.

- Commercial study & comparisons between conventional façade system & photovoltaic façade system.
- A detailed study in terms of the life span and indirect benefits.
- Report on the reduction of greenhouse gases emissions to electric power usage.

The methodology for researching photovoltaic facades in terms of different aspects (commercial, technical, aesthetics) will be carried out per the following steps:

- Selecting a prototype model for a commercial and residential building
- Evaluate the model climatic properties like temperature, sun orientation.
- Creating a base model with conventional façade systems.
- Evaluating the general energy consumption with conventional facades.
- Development of the same model now with integrated photovoltaic façade systems, keeping following factors:-
 - i. Tilted façade: Good idea to increase yield while paying attention to overheating λ
 - ii. Where to integrate. In vision and no vision. If transparent, what is required, g-factor, v, etc.... λ
 - iii. Shadows often exist, study to carry λ
 - iv. Determine zones not allocable to PV: near doors, trees, details, terraces ... λ
 - v. Insulated modules are not back-ventilated λ
 - vi. Where and how are the wiring ways going inside the building? Construction details.
- Detailed cost analysis.

تستهلك المباني في جميع أنحاء العالم ما يقرب من 40 ٪ من الطاقة، وتستند عمليات البناء إلى مصادر غير متجددة للطاقة، مثل التهوية وتكييف الهواء والكهرباء والتدفئة، مما يساهم في أكثر من 33 ٪ من غازات الاحتباس الحراري .

ولاستدامة أجيالنا المقبلة من الآثار الضارة لغازات الدفيئة، فإن المباني لديها إمكانات كبيرة. وإذا كان المبنى يقلل إلى حد كبير من احتياجات الطاقة من خلال تحقيق مكاسب في الكفاءة بحيث يمكن تزويد توازن احتياجات الطاقة بالتكنولوجيات المتجددة، فإن ذلك المبنى يمكن أن يطلق عليه بناء الطاقة صفرًا.

ولتحقيق مفهوم المبنى الصفري، ينبغي تصميم المبنى لتقليل استهلاك الطاقة إلى أدنى حد ممكن. يجب أن يكون المبنى قادراً على إنتاج الطاقة على نفسه. لتحقيق الهدف من هذا المفهوم، وبناء المغلف، واجهات هي المفتاح المحتمل النهائي في المغلف الذي سيؤدي إلى الحد الأدنى من استهلاك الطاقة وأيضاً إنتاج الطاقة بمساعدة واجهات الضوئية

واجهات الكهروضوئية المتكاملة هي اقتراح حل مهم. غير أن تنفيذه مصحوب بتحديات كبيرة من حيث تعقيد العمليات والتكنولوجيات المعنية وإمكانية تكييف هذه الحلول مع مختلف المناطق الجغرافية ذات الظروف المناخية الخاصة .

يهدف هذا البحث إلى تقييم جدوى تنفيذ الواجهات الكهروضوئية في المشاريع التجارية والسكنية. وسيتم دراسة الجدوى من حيث الوفورات الإجمالية في استخدام الطاقة، والجدوى الاقتصادية، ودراسة مفصلة تكنو تجارية ومقارنة مع أساليب الواجهة التقليدية.

الهدف من دراسة الدراسة هو:

- تفاصيل إنتاج الطاقة.
- التأثيرات على التكلفة مقارنة باستهلاك الطاقة الكهربائية.
- الجماليات المحتملة للواجهات الضوئية.
- البحوث والتطورات في تصميم المباني للتطبيق الأقصى للواجهات الضوئية.
- دراسة تجارية ومقارنات بين نظام الواجهة التقليدية ونظام الواجهة الضوئية.
- دراسة مفصلة عن مدى العمر والفوائد غير المباشرة.
- تقرير عن تخفيض انبعاثات غازات الدفيئة إلى استخدام الطاقة الكهربائية.

سيتم تنفيذ منهجية البحث في الواجهات الكهروضوئية من حيث الجوانب المختلفة) التجارية والتقنية والجماليات (وفقاً للخطوات التالية:

- اختيار نموذج أولي لمبنى تجاري وسكني
- تقييم الخصائص المناخية النموذجية مثل درجة الحرارة، واتجاه الشمس.
- إنشاء نموذج قاعدة مع أنظمة الواجهة التقليدية.
- تقييم الاستهلاك العام للطاقة بالواجهات التقليدية.

تطوير نفس النموذج الآن مع أنظمة الواجهة الضوئية المتكاملة، مع الحفاظ على العوامل التالية

- .I الواجهة المائلة: فكرة جيدة لزيادة العائد مع الانتباه إلى ارتفاع درجة الحرارة
- .II أين تتكامل في الرؤية ولا رؤية. إذا شفافة، ما هو مطلوب عامل، الخامس، الخ ...
- .III الظلال غالبا ما توجد، ودراسة لحملها.
- .IV تحديد المناطق غير قابلة للتحديد إلى PV بالقرب من الأبواب والأشجار والتفاصيل والمدرجات □ ...
- .V الوحدات المعزولة ليست ذات تهوية خلفية.
- .VI أين وكيف تسير طرق الأسلاك داخل المبنى؟ تفاصيل البناء.

- تحليل مفصل للتكاليف.

ACKNOWLEDGEMENT

I highly esteem my supervisor, Dr. Hanan M Taleb (Ph.D., M.Arch, MSc, MA, BA) for the guidance and assistance accorded to me in the successful development of this research.

I also recognize and appreciate the British University in Dubai community, staff, and colleagues for their support, cooperation, and availing their amenities and facilities to facilitate the research.

I would also like to thank and appreciate my family, friends, and acquaintances for their support and backup. Through their support, love, and care, I successfully reached the end of my Master's studies.

DEDICATION

First of all I dedicate this study to Almighty God, who has given me all the strength and wisdom to execute this work.

To my parents Mr. Mathai K.M and Mrs. Aney Mathew who have paved the way of the light of knowledge to my life.

To my loving wife Mrs. Jelitta Jose and my kids Antony, Rose and Francis for all the inspirations and moral supports.

Table of Contents

List of Figures	iv
List of Tables.....	ivi
List of Abbreviations.....	viii
1 CHAPTER 01: INTRODUCTION	1
1.1 Global Warming & Green House Effects.....	2
1.2 Contribution of Buildings to Green Houses Gases.....	3
1.3 Zero Energy Buildings.....	4
1.4 Building Integrated Photovoltaic Facades	5
1.5 Energy Utilization by Buildings in UAE	6
1.6 Motivation Of Work.....	7
2 CHAPTER 02: LITERATURE REVIEW	8
2.1 Overview	9
2.2 Buildings & Climate Change.....	10
2.3 Green Building's & Its Role in Fight against Climate	10
2.4 Definition of Zero Energy Building	12
2.5 Steps to Zero Energy Buildings.....	12
2.6 The implication of Zero Energy Buildings.....	15
3 CHAPTER 03: BUILDING-INTEGRATED PHOTOVOLTAIC FACADES.....	20
3.1 Overview	21
3.2 Description	21
3.3 Orientation of Base Case Model	24
3.4 Façade Characteristics (Base Model Design).....	25
3.5 Photovoltaic Systems.....	30
3.6 SOLAR PV SYSTEMS ON BUILDINGS.....	37
3.6.1 Functional & Constructive Aspect.....	37
3.6.2 Formal Aspects and Aesthetics	39

3.6.3	Photovoltaic System Position & Sizing	39
3.7	Façade Characteristics (Base Model Design with Photovoltaic Panels)	40
3.7.1	Advantages of Amorphous solar silicone P.V. Glass:-	41
3.7.2	Natural Lighting & Selective Filters	41
3.7.3	Insulation Properties Amorphous silicon photovoltaic glass follows both thermal & sound insulation, which could fabricate as per requirement.	42
3.7.4	Standard Panel Sizes Available For Amorphous Photovoltaic Panel.....	43
3.8	Fixing Methodology	45
3.9	General Photovoltaic Estimation	47
3.10	Feasibility Study	50
3.11	Other advantages of Building-integrated Photovoltaic & Green Building Design	63
3.12	Hypothesis and Assumptions	63
4	CHAPTER 04: METHODOLOGY & STRATEGIES	74
4.1	Overview	75
4.2	Field Studies/ Physical data collection	75
4.3	Properties and characteristics of existing building material on Y-towe Adnec building ...	76
4.3.1	Advantages and Disadvantages of Field Studies	89
4.4	Literature Review	89
4.4.1	Advantages and Disadvantages of Literature Review	90
4.5	Simulation and Modelling	90
4.5.1	Advantages and Disadvantages of Simulation and Modelling	91
4.6	Adopting a Multidisciplinary Approach	92
4.6.1	Advantages and disadvantages of the multidisciplinary approach.....	92
4.7	Integrated Environmental Studies- Virtual Environment (IES-VE)	93
4.7.1	Advantages and Disadvantages of IES-VE	94
4.8	IES VE Integration with Sketch-Up	94
4.9	Sun Path Analysis	95
4.10	Calculations and Estimations	99
5	Chapter 05: RESULTS AND DISCUSSION	1022
5.1	Overview	1033

5.2	Sun Path Analysis	1033
5.3	Energy Saving Situation with Existing Building Material	1033
5.4	Energy Efficiency	1033
5.5	Cost reduction.....	1033
5.6	Cost-Benefit vs. Investment.....	1044
6	Conclusion	1044
	Bibliography.....	1055
	Indices.....	10909

List of Figures

Figure 1; Pichart indicating the components of GHGs in percentages. CO2 forms the largest portion.	2
Figure 2; Carbon emissions are usually a result of our social-economic activities like industrial production processes.	3
Figure 3; Components of a green building.	5
Figure 4; The use of BIPV systems in reducing buildings' carbon footprints and attaining energy sufficiency.	5
Figure 5; Principles of Estidama standards.	17
Figure 6; The Y tower Adnec Building.	22
Figure 7; The Y tower Adnec Building.	22
Figure 8; Floor Plan the Y tower Adnec building.	23
Figure 9; The Y Tower Adnec building sun path analysis. (Source; Curic Sun Path Analysis-SketchUp extension).	24
Figure 10; SUN PATH DIAGRAM Invalid source specified.	25
Figure 11; Double glazed glass.	27
Figure 12; U-Value weighting in building floors.	30
Figure 13; Schematic representation of the possible uses of solar harnessed electricity.	33
Figure 14; Components of a home solar mini-grid.	34
Figure 15; Mono-Crystalline Silicon PV Cell and Poly-Crystalline Silicon PV Cell.	35
Figure 16; Tree diagram showing various types of PV cells.	35
Figure 17; Types of PV cells.	35
Figure 18; Typical Solar Aesthetic Panel.	37
Figure 19; The Area of Study, Y Adnec Towers, Abu Dhabi. Source; (Author). The building existing Double Glazed glass will be replaced remodelled with ACP which have the ability to harness solar energy and save energy trough using solar energy and natural lighting to replace the need for artificial lighting and grid electricity.	40
Figure 20; Aesthetic PV Panels.	42
Figure 21; Standard sizes available in the market for Amorphous Photovoltaic Panels.	44
Figure 22; Components of an Aesthetic Energy Panels.	45
Figure 23; Installation of ACP material.	46
Figure 24; U Value of the proposed ACP material.	46
Figure 25; The Average daily electricity production from the given system (kWh).	48
Figure 26; The Average monthly electricity production from the given system in(kWh).	49
Figure 27; The Average daily sun of global irradiation per square meter received by the modulus of the given system in (kWh/m2).	49
Figure 28; The Average sum of global irradiation per square meter received by the modules of the given system in (kWh/m2).	50
Figure 29; Aesthetic ACP material.	51
Figure 30; GEB Considerations.	52
Figure 31; Energy Savings with the adoption of Solar Glass.	53

Figure 32; Rate of investment returns on the installation of solar glass panels.	53
Figure 33; Energy Reduction graphs within 30yrs of adopting ACP Panels and PV Panels.	57
Figure 34; Reduction in HVAC Demand.	58
Figure 35; Average Reduction in Energy Demand vs. Amount Invested.	61
Figure 36; Fist step in modelling the site area was site allocation and design of the ground floor plan. ..	65
Figure 37; Concstruction of the pillars, floor slabs, and wall cladding.....	66
Figure 38; Replacing existing wall material with ACP. This involves changing building properties in the IESVE extension on Stech-up. As well as the alloactaion of different settings and characteristics like thermal performance.	67
Figure 39; Front elevation of the complete remodelled building.	67
Figure 40; Side elevation of the proposed building.	68
Figure 41; Abu Dhabi's Day length chart (Source; Adrewmarsh.com 3D Online Sun Path Analysis Tool)	96
Figure 42; Abu Dhabi's Sun Path Analysis (Source; Adrewmarsh.com 3D Online Sun Path Analysis Tool)	97
Figure 43; The Y Tower Adnec Building's Sun Path analysis (Morning hours) (Source; Curic Sun Path Analysis-SketchUp extension). Note the shaded north-west and south-west façade during the morning hours.....	98
Figure 44; The Y Tower Adnec building sun path analysis. (Source; Curic Sun Path Analysis-SketchUp extension).	98

List of Tables

Table 1; Sectors that contribute to the emission of GHGs	2
Table 2; Aspects of DGU glass. Source; KMM Group.....	28
Table 3; Conversion efficiency in different PV modules.....	366
Table 4; Calculated with energy-efficient light bulbs of 6W.....	477
Table 5; Total reduction in energy demand 30yrs, after adopting BIPV technologies and consequent reduction in HVAC energy use.	54
Table 6; TOTAL REDUCTION IN ENERGY DEMAND (EUR)	55
Table 7; TOTAL REDUCTION IN ENERGY DEMAND (EUR)	566
Table 8; Energy Cost Per kWh.....	60
Table 9; Return on Investment.	62
Table 10; Calculations of the thermal transmittance (U) value of Hollow-Block wall material (100 mm Thick)	76
Table 11; Thermal transmittance (U-value) of the 100mm thick Hollow Blocks.....	77
Table 12; Calculations of the thermal transmittance (U) value of Hollow-Block wall material (150 mm Thick).....	77
Table 13; Thermal transmittance (U-value) of the 150mm thick Hollow Blocks.....	78
Table 14; Calculations of the thermal transmittance (U) value of Hollow-Block wall material (200 mm Thick)	78
Table 15; Thermal transmittance (U-value) of the 200mm thick Hollow Blocks.....	79
Table 16; Calculations of the thermal transmittance (U) value of Insulated-Block wall material (200 mm Thick)	79
Table 17; Thermal transmittance (U-value) of the 200mm thick Insulated Blocks.....	80
Table 18; Calculations of the thermal transmittance (U) value of Insulated-Block wall material (250 mm Thick)	80
Table 19; Thermal transmittance (U-value) of the 250mm thick Insulated Blocks	81
Table 20; Product configuration table	81
Table 21; Calculations of the thermal transmittance (U) value of Insulated-Block wall material (300 mm Thick)	82
Table 22; Thermal transmittance (U-value) of the 300mm thick Insulated Blocks	83
Table 23; Calculations of the thermal transmittance (U) value of Solid-Block wall material (100 mm Thick)	83
Table 24; Thermal transmittance (U-value) of the 100mm thick Solid Blocks	84
Table 25; Calculations of the thermal transmittance (U) value of Solid Block wall material (150 mm Thick)	84
Table 26; Thermal transmittance (U-value) of the 150mm thick Solid Blocks	84
Table 27; Calculations of the thermal transmittance (U) value of Solid-Block wall material (200 mm Thick)	85
Table 28; Insulated glass properties performance calculations (Source; Guardian Glass)	86
Table 29; Insulated glass properties sum PRODUCT CONFIGURATION marry table (Source; NFRC 2010)	86

Table 30; Rockwool material thermal conductivity.	88
Table 31; Rockwool acoustic properties.	88
Table 32; Rockwool nominal material density and fire protection capabilities.	89
Table 33; Estidama Renewable Energy (RE) generation calculations of Y Towers Adnec (Source; Author).	99
Table 34; Panel Yield Calculation (Source; Author)	99
Table 35; Energy generation calculation table (Source; Author).....	100
Table 36; Energy generation potential and unit cost benefit per year calculations (Source; Author)	100
Table 37; Cost vs returns analysis. (Source; Author).....	100
Table 38; Energy efficiency calculation with aesthetic PV panelled glass. (Source; Author).....	101

List of Abbreviations

AC: Alternating Current

AC: Air Conditioning

ACDB: Alternating Current Distribution Boards

ACP: Aluminium Composite Panel

ASCE: Association Society of Civil Engineers

ASTM standards: American Society for Testing and Materials

BIPV: Building Integrated Photo-voltaic Systems

BIM: Building-integrated Management Systems

BS 3958-5:1986: Thermal insulating materials building standards.

CFLs: Compact Fluorescent Lamps

CO₂: Carbon IV Oxide

CIGS: Copper Indium Gallium Selenite

CSR: Corporate social responsibility

DC: Direct Current

DEA: Department of Energy Abu Dhabi

DEWA: Dubai Electricity & Water Authority

DGU: Double Glazing Unit

DIN 52271:1981: Standard for testing of mineral fibre insulating materials

EN Standards: European Standards

EUI: Energy Use Intensity

GCC: Gulf Cooperation Council

GHGs: Green House Gasses

GBRS: Green Building Regulation and Specifications

HVAC Systems: Heating, ventilation, and air conditioning Systems

IES- Ve: Integrated Environmental Studies – Virtual environment

kWh: kilo Watts per hour

LED Lighting: Light Emitting Diode Lighting

NZEB: Net Zero Energy Building

PV: Photo-voltaic

PVB: Polyvinyl butyral

RE-1: Percentage Energy Savings from A Building (Estidama Pearl Regulations)

RE-6: Percentage of Energy from Renewables as per Estidama Pearl Regulations

ST: Statipn Transformer

UAE: United Arab Emirates

UHI: Urban Heat Islands

UN: United Nations

UNEP: United Nations Environmental Program

USGBC: United States Green Building Council

UV Rays: Ultra-violent rays of the sun

U-Value: Thermal transmittance value

ZEB: Zero Energy Buildings

ZET: Zero Energy Technologies

1 CHAPTER 01: INTRODUCTION

1.1 Global Warming & Green House Effects

For the past half a century or so, greenhouse gas emissions have become a contentious issue of discussion, gaining much social and political attention (Benestad 2005). There are fears that we might be driving ourselves to extinction through our daily human activities and practices (Gregory, Leiserowitz & Failing 2006). For these reasons, researchers, scientists, and innovators have been on their feet trying to develop more innovative, sustainable, and resilient systems and technologies to help mitigate and adapt to social, economic, and environmental development.

The greenhouse gases are comprised of: -

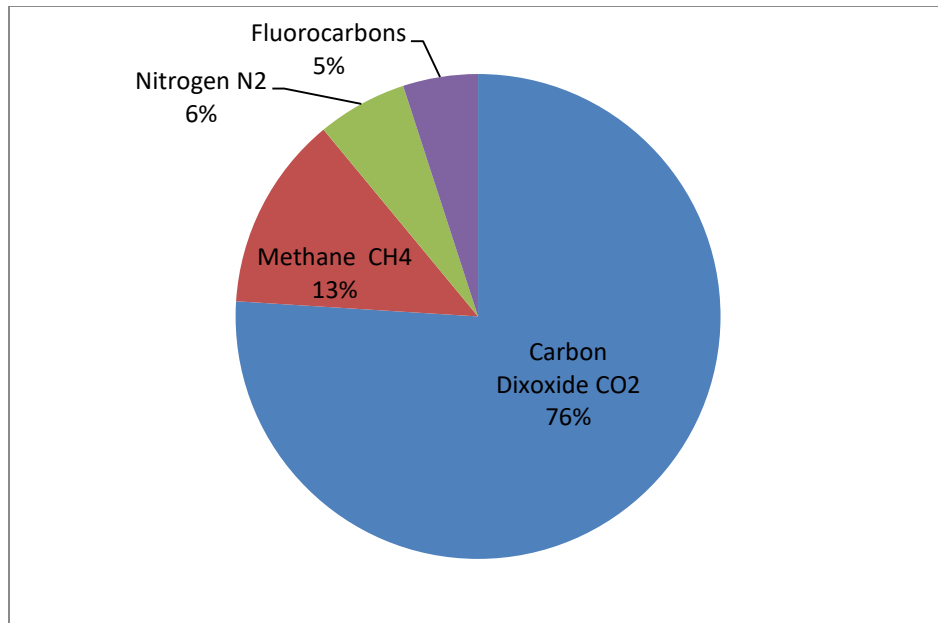

Figure 1; Pie chart indicating the components of GHGs in percentages. CO2 forms the largest portion.

Therefore, CO2 is a significant contributor to increasing the global temperature (Sagheb, et al., 2011).

Researches show that eight significant sectors annually release a considerable amount of Green House Gases, thereby CO₂, into the air, causing global warming.

Table 1; Sectors that contribute to the emission of GHGs

Power Station	21.3 %
Industrial Processing	16.8 %
Transportation Fuels	14.0 %
Agricultural By-Products	12.5 %
Fossil Fuel Retrieval Processing & Distribution	11.3 %

Commercial & Other Sectors	10.3 %
Land Use & Biomass Burning	10.0 %
And Waste Disposal & Treatment	3.4 %

We will discuss the emission of CO₂ from the building industry, which shares around 80% of emissions, and propose a strategy to aid in reducing the carbon footprints of buildings through the adaptation of green energy technologies, with BIPV systems being the main issue of discussion.

1.2 Contribution of Buildings to Green Houses Gases



Figure 2; Carbon emissions are usually a result of our social-economic activities like industrial production processes.

As the world gets more advanced and modernized daily, millions of new buildings are constructed every year. Likewise, advancement in material engineering & technology is leading to the development of modern construction materials. In this process of modernization, the biggest missteps were to abandon our traditional knowledge.

A substantial amount of energy is consumed in producing exhaustive building materials and frequent energy consumption for cooling and heating the indoor environment. The U.N. Environmental Programme (UNEP, 2009), have indicated that CO₂ emissions have been on the increase as a result of human activities like;

- Extraction of raw materials
- Manufacturing and distribution
- Transport
- Housing and structures

CO₂ emissions are essential measures for assessing the use and applicability of various materials and building products by assessing their effects on the environment, sustainability, and desirability in construction (Sagheb, et al., 2011).

To illustrate the same, we will take a typical building and estimated contribution to greenhouse effects with & without photovoltaic façades.

1.3 Zero Energy Buildings

As per recent reports and survey, buildings play a crucial impact on energy use and the environment. A Commercial & Residential building consumes almost one second of the primary energy & one-third of the electricity around the globe (Torcellini, et al., 2006). New buildings are coming up fast as compared to the old ones demolishing. Energy consumption in the commercial & residential building sector will continue increasing until building designs and materials are reviewed to produce enough energy to offset the growing energy demand of these buildings.

In concept, a Zero Energy building is a building with significantly reduced energy wants through efficiency gains from reduced consumption, such that the Balance of the energy needs can be supplied by renewable technologies (Lu, et al., 2019). However, despite our use of the phrase "zero energy," we lack a standard definition—or a shared understanding—of what it means. Our research used a sample of current generation low energy buildings to explore the concept of zero energy—what it means, why a clear and measurable definition is needed, and how we have progressed toward the ZEB goal.

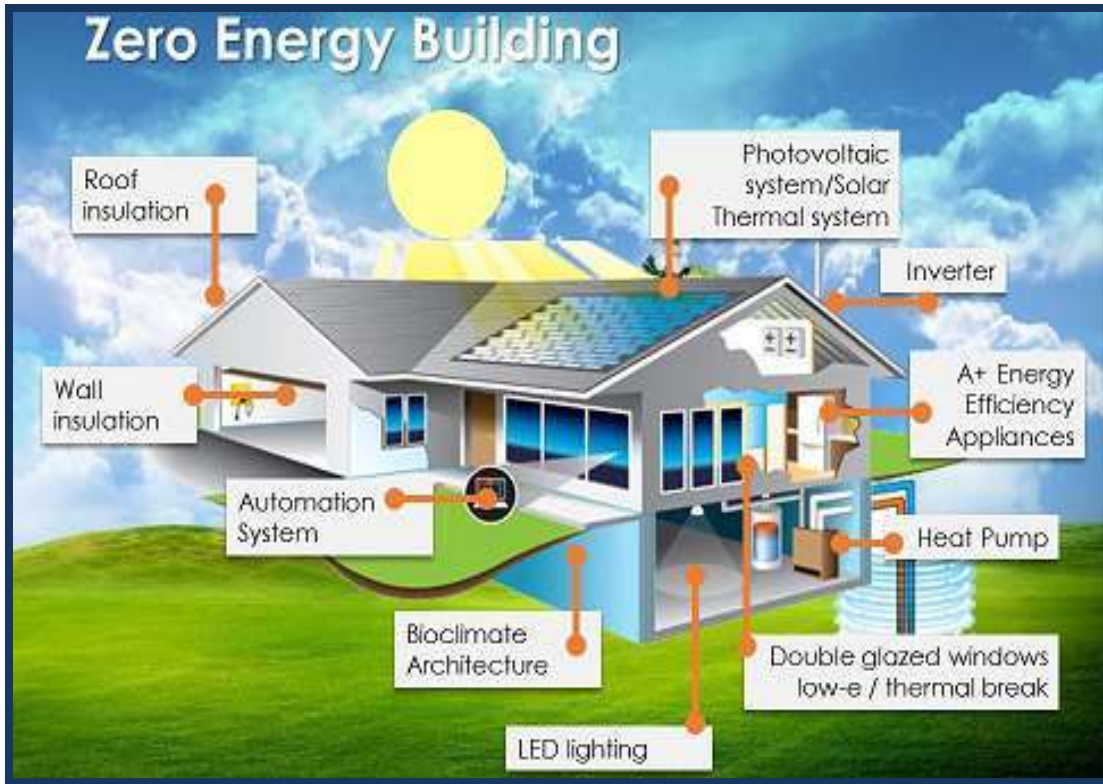

Figure 3; Components of a green building.

1.4 Building Integrated Photovoltaic Facades



Figure 4; The use of BIPV systems in reducing buildings' carbon footprints and attaining energy sufficiency.

Building Integrated Photovoltaic (BIPV) provides such an opportunity through clean micro-energy generation adaptable to various building designs (Attoye, et al., 2017). Several studies

indicate that the application of BIPV leads to substantial energy savings; this results in related gains in terms of energy consumption and reduction of pollution sources. Moreover, IPV reduces the damage done to the ecosystem through conventional energy ways of relieving and alleviating the increasing economic and environmental costs of using fossil fuels for energy generation (Attoye, et al., 2017).

Technological advancements and innovation have evolved BIPV into a P.V. application with the ability to deliver electricity at a comparatively lower cost than grid electricity for specific end-users in certain peak demand niche markets. As a contemporary material available to the building and construction industry, BIPV serves as part of the Building's envelope and energy source. BIPV systems can be more cost-effective because their composition and location replace several conventional components and provide considerable gains. These include; savings on materials and lower electricity costs, reduced use of carbon fuels, decreasing carbon and greenhouse gas emissions, and improved architectural image of the Building (Osseweijer, et al., 2018).

1.5 Energy Utilization by Buildings in UAE

The UAE has its eyes focused on achieving sustainable infrastructure development for renewable power generation. However, the population is growing day by day, demand for electricity and water continues to grow faster (Mohammad & Madani, 2012). According to a survey conducted, around 6% increase is recorded in annual power demand throughout the past decade (Ministry of Energy and Industry, 2017).

The energy sector plays a vital role in shaping the UAE's internal and external policies. Since discovering oil and gas more than half a century ago, the UAE became a central player in the global hydrocarbon energy market (Khondaker, et al., 2016).

Owed to able and visionary leadership, the UAE is in the process of diversifying its energy mix to sustain its progress and at the same time minimize the environmental impact that may arise from burning fuel (Ministry of Energy and Industry, 2017).

Therefore, it was decided that the traditional energy sources, oil and gas, should not be considered the main drivers of the economy and energy generation process.

Further, the UAE is developing local capacity and expertise in these critical technologies while fostering and enhancing international cooperation and resource conservation through investing in research institutions and projects. The UAE has a long-term strategy with a skilled team of researchers, innovators, and scientists required to create sustainable solutions for energy resources.

Although oil and gas have been the primary sources of fuel and energy in the UAE, the energy sector in the UAE is undergoing a transformation targeting the UAE's energy mix diversification.

Most of the energy in the UAE is generated from natural gas, that is (110 billion kilowatt-hours in 2013). The UAE is planning to integrate all the emirates' natural gas distribution networks; this swill is essential in alleviating some of the peak-demand shortfalls experienced in the past.

The UAE's energy aims to ensure access to affordable, reliable, and modern energy services, promote renewable and sustainable energy sources like solar energy in the global energy mix, and double the global energy efficiency rate.

1.6 Motivation Of Work

The United Arab Emirates (UAE) has been gradually developing over the past two decades, becoming a booming hub for trade and commerce. With the ongoing fast-paced development of the region, the energy demand is growing rapidly compared to its production capacity, highlighting the need to implement energy conservation measures.

Technology continues to evolve and change as researchers and scientists come up with innovations. As a result of the adoption of modern technology, more emphasis and resources have been placed on energy efficiency, thus seeing the transition from a mere possibility to a necessity. The need to reduce carbon footprints and conserve the environment has led to drastic changes in the building and construction sectors' practices and behaviour, from management, planning to integration. The concept of Zero Energy Buildings or Net Zero Energy Buildings (NZEB) is quickly gaining momentum for environmentally conscious authorities (Sagheb, et al., 2011).

2 CHAPTER 02: LITERATURE REVIEW

2.1 Overview

Nations around the world are pushing up their game in the fight against climate change.

It's important to remember and note the crucial role and contribution that human beings can make.

"Change only happens when individuals take action."

"There's no other means if it doesn't start with people."

The goal is simple. Carbon dioxide is the climate's worst enemy. It's released when oil, coal, and other fossil fuels are burned for energy—the energy we use to power our homes, cars, and smartphones. Using less of it can curb our contribution to climate change while also saving money.



The built environment happens to be among the most significant contributors of climate change and global warming, with approximately 40% of the total primary energy used in all sectors and 36% of the global GHG emissions in the world. However, many remarkable efforts and innovative solutions are made to address and mitigate the high energy use of buildings and communities. Globally, several initiatives and regulations have been assigned and set as minimum essential requirements to all new and existing buildings. Moreover, over the past few years, many high-performing building concepts have emerged beyond the building envelope, contributing to decreased energy demand and CO₂ emission at the community level, such as the Zero Energy Buildings. The development of the Zero Energy Building framework is an essential measure for taking the UAE's & world's present and future climate initiatives to the next level.

In this literature review, we will be studying a detailed understating of the definition of Zero Energy Building and solar energy as sources of renewable energy supply. Firstly, the chapter investigates previous studies on the trends, concepts, global definitions, and parameters of Zero Energy Buildings to reduce energy demand and carbon footprint. Furthermore, the chapter

highlights the importance of the zero-energy concept and its challenges and opportunities in the UAE.

Secondly, many papers discuss the various passive and active energy-efficient strategies, urban level integration of photovoltaic systems, various photovoltaic technologies, and parameters that impact energy balance and economic feasibility. Case studies highlighting the strategies and the approach using different renewable systems, main barriers, and opportunities in the field of Zero Energy Buildings that play in the global and UAE's road to sustainability

2.2 Buildings & Climate Change

The commercial and residential building and housing sector account for 39% of carbon dioxide (CO₂) emissions in more than any other sector; buildings alone are responsible for more CO₂ emissions annually. The most significant percentage of these emissions is from fossil fuel combustion to provide heating, cooling, lighting, power appliances, and electrical equipment. By transforming the built environment to leaning more towards energy-efficient and climate-friendly, the building sector can significantly reduce the threat of climate change (UNEP, 2009).

We should also consider the other CO₂ emissions attributable to buildings, such as the emissions from the manufacture, transportation of building construction materials, demolition materials, and transportation associated with urban sprawl, which results in a more significant impact on the climate

As per studies, buildings consume approximately 70% of the electricity load and up to 40% of the net global energy annually (UNEP, 2018). The most significant contributing factor to CO₂ emissions from buildings is their use of electricity.

The energy impact of buildings on the environment is likely to be even more significant when considering other energy uses within buildings. A good example is an energy embodied in a single building's envelope, which equals eight to ten times the energy used annually to heat and cool the building. Buildings have a lifespan of fifty to a hundred years, during which they continually consume energy and produce CO₂ emissions. Constructing half of the new commercial use buildings to use 50% less energy would save millions of metric tons of CO₂ annually for the life of the building; this is the same as doing away with more than 1 million vehicles off the road every year. According to the UNEP (UNEP, 2018), it is possible to reduce these energy consumptions in buildings by thirty to eighty per cent.

2.3 Green Building's & Its Role in Fight against Climate

Studies had shown that emissions of CO₂ and other greenhouse gases from human activities have been on the rise, especially in this century (Wigley, et al., 1981). The impacts will be profound, including rising sea levels, frequent floods, droughts, and pandemics like the recent Covid-19 pandemic. It is essential to control and mitigate these adverse effects of climate change before reaching a tipping point where we won't do a thing.

Meeting the challenge will require us to make innovations and technologies that will change our production process and practices and our daily life practices and behaviour. Green buildings happen to be one of the most effective strategies for mitigating the adverse impacts and challenges of climate change because the technology to make substantial reductions in energy and CO₂ emissions already exists. (USGBC, 2005) Highlights that an average LEED-certified building consumes 32% less energy and saves 350 metric tons of CO₂ emissions yearly. Modest investments in energy-saving, environmental conservation, and other related technologies often result in sustainable and livable buildings and communities beneficial to the environment and the economy, social, and health contributions (Amiri, et al., 2019).

According to (USGBC, 2005), Green Buildings are instrumental in the reduction of CO₂ emissions while at the same time improving energy savings, electricity bills, and environmental conservation.



The following measures can be taken to improve the performance of a building in energy conservation and savings. They are :

- Use efficient heating, ventilation, and air conditioning systems and operations and maintenance of such systems to assure optimum performance.
- Using state-of-the-art lighting and optimizing daylighting.
- Using recycled content building and interior materials.
- Reducing potable water usage.
- Using renewable energy.
- Implementing proper construction waste management.

- Positioning of the buildings near public transportation systems.
- Using locally produced and sourced building materials.

2.4 Definition of Zero Energy Building

Zero Energy Building concepts are gaining social and political popularity and support (Lu, et al., 2019). Zero energy and the topic of sustainable social, economic, and environmental development has been growing rapidly growing.

Advantages and disadvantages of standard definitions in Zero Energy Technologies (ZET) (U.S. Department of Energy, 2015):

- Net Zero Site Energy: A site Zero Energy Building produces as much energy as the total energy the Building uses in a year, considering factors like the site's environmental conditions.
- Net Zero Source Energy: A source Zero Energy Building produces as much energy as it uses within the span of a year when accounted for at the source. The 'source energy' refers to the primary energy source and type used to generate and deliver the energy to the building or site. To calculate a building's total energy source, the imported and the exported energy used in the facility is multiplied by the appropriate site-to-source conversion multipliers.
- Net Zero Energy Costs: In a cost Zero Energy Building, the building owner gets an equal amount of money from the total energy consumed by exporting and selling energy to the primary power grid.

2.5 Steps to Zero Energy Buildings

I. Smart Building Design

Adapting smart building designs will be essential towards having cost-efficient and zero-carbon energy buildings. Designers and architects and builders should be familiar with all the steps involved in building a net-zero energy building and design the Building to implement these steps as cost-effectively as possible. There are several design measures to which builders should ask designers to pay special attention. Clear communication between the builder and designer will ensure that these critical details do not fall through the cracks (Lu, et al., 2019).

II. Using Energy Modeling

Energy modelling happens to be another significant measure where during the design phase of the Building, energy use is estimated using energy modelling software to ensure that net-zero energy is achieved while keeping production and consumption costs down. From the results obtained, ideal design choices can be made or modified to balance and improve building performance and construction cost (Neshat, et al., 2014).

III. Super-Seal the Building Envelope

Ensuring that the building envelope is super-sealed can be a cost-effective measure the building and construction industry can take to improve the energy efficiency of zero energy buildings. Several proven steps of ensuring the Building or facility have been air-sealed, although the choice is based on the area's climate, budget, and the skills needed to set up the project.

IV. Super-Insulate the Building Envelope

After making the Building airtight, super-insulating the Building may be the second most cost-effective strategy for creating a zero energy home. As mentioned in step 2 above, energy modelling can help us optimize energy consumption by adding further insulation levels to ceilings, walls, and floors, thus reducing energy loss. The selection of ideal strategies will make it easier to insulate the building envelope and minimize thermal bridging.

V. Adopting Efficient Water Heating Mechanisms

Heating water is usually the most significant energy expense in a zero energy home after heating and cooling. So designers and builders need to select and locate efficient hot water heating technology and other measures to minimize hot water.

VI. Use Insulated Windows and Doors

Ventilation, doors, and windows happen to be huge contributors to energy loss. Proper insulation and covering of such surfaces will help make energy use and conservation in a premise efficient. Control heat loss & gain through windows and doors, which can be done by selecting appropriate window & door products, carefully locating them, and adequately optimizing their size & orientation.

VII. Use the Sun for Solar Tempering

Using the sun for heating through south-facing windows during the winter lowers heating costs. Shading those same windows in summer reduces cooling costs. Solar tempering aims to optimize the passive use of solar energy to heat buildings without incurring any additional cost of thermal mass needed to achieve maximum passive solar heating.

VIII. Create an Energy-Efficient, Fresh Air Supply

Since zero energy homes are so airtight, continuous fresh filtered air and moisture control are critical to its success. The need for ventilation has a silver lining: zero energy homes are healthier and more comfortable than traditional homes. Highly energy-efficient ventilation systems are essential, especially when it comes to air circulation and expelling stale air while conserving the heat energy in premises, thus reducing the need, energy, and cost incurred in powering and introducing air circulation appliances and devices (Ben Ghida, 2019).

IX. Select an Energy-Efficient Heating and Cooling Mechanism

It is essential to adapt and use energy-efficient and cost-efficient heating and cooling systems if we are going to achieve our net-zero energy goals. A good choice is an air source ductless heat pump, also called a mini-split heat pump. These systems are highly efficient and do not have the shortcomings of central, forced-air systems or the high costs of thermal heat pumps (Wolfe, et al., 2009).

X. Install Energy Efficient Lighting

While optimizing light for residents, minimizing energy use for lighting is essential in zero energy home design and construction. LED lights are the best lighting option in conventional bulbs and fluorescent tubes that used more energy. They are more energy-efficient than CFLs, which last for many years longer and contain no mercury components. In addition, they are essential in meeting a variety of lighting needs, from very bright white lighting to soft and warm lighting. Selecting the right LED lights for the requirements, strategically locating and positioning lights, and utilizing natural light from the sun through proper building orientation reduces the amount of energy needed to light the premises (Wolfe, et al., 2009).

XI. Use of Energy Efficient Appliances

In a zero energy home setting, just over 40% of the total energy is used for heating, cooling, and hot water. Electrical appliances and plug loads account for up to 60% of the total energy load. Thus, selecting the ideal and energy-efficient appliances and managing "phantom" plug loads for electronics is crucial. "Phantom" loads are hard to discover while they continue to draw quite considerable amounts of energy irrespective of the time of the day and whether or not the devices are being used. Several homes modelled and built to zero energy standards have not met energy requirements in practice because of the unanticipated energy waste caused by "phantom" plug loads on electronics (Wolfe, et al., 2009).

XII. Use of Solar Energy

Grid-tied solar photovoltaic (P.V.) panels provide the most cost-efficient form of renewable energy for a zero energy home. They can power all the home's energy needs, including heating and cooling systems, lighting, and appliances. However, setting up a solar mini-grid for your home happens to have a high initial cost of installation, and strategies for reducing or mitigating those costs, like availing funds through activities like green finance, are important to consider (Wolfe, et al., 2009).

2.6 The implication of Zero Energy Buildings Global Significance

Studies found that a cleaner environment increased from quality ventilation, lighting, energy, and water in green buildings and communities, carbon emissions have decreased through renewable energy use (Umar, et al., 2013).

Zero energy buildings provide a higher quality of urban life with a clean environment and carbon-free energy for daily use, hence better individual user satisfaction, better health, and increased productivity. This also reduces dependency on conventional energy resources such as fossil fuels and natural gas, which leads to global warming. The energy generated using renewable technologies improves their community energy efficiency, leading to cost savings for residents residing in the community, reducing volatile energy prices (Umar, et al., 2013).

Provides energy security as it does not wholly rely on the national utility network, especially for developing countries where energy sources are not constant.



Energy autonomy has enhanced community reputation and employment opportunities. Community awareness has to be made professionally for improving the local construction market towards green buildings. Thus contributing to the creation of employment and improving community living standards (Hamilton, 2015). Encouragement of government, private organizations, developers, and investors must incorporate sustainable technologies in their respective development projects. UAE government focuses more on all governmental projects with an Estidama Pearl 2 rating and a minimum of Estidama pearl 1 rating for even private villas (Ramani & García De Soto, 2021).

UAE Significance

According to UNEP (UNEP, 2009), the built environment and industries are the largest generators of greenhouse gases and other forms of pollution. This offers significant opportunities to alleviate environmental pollution and promote the sustainable use of resources. The United Arab Emirates, hindered by natural constraints, has tried to shift towards more sustainable practices in design and construction (Issa & Al Abbar, 2015).

With the development and use of green building codes in the United Arab Emirates (UAE), the country has shown its focus and determination to become more environmentally friendly, with record-breaking developments (Mohammad & Madani, 2012). The region has well-established green building codes: the Abu Dhabi Urban Planning Council's Estidama; Dubai Municipality's Green Building Regulations. The adoption and use of Green building codes and systems in the

UAE demonstrate the efforts and financial investments made by the government and organizations in streamlining sustainability in the construction industry (Issa & Al Abbar, 2015). Whether the codes are being used for existing buildings or new construction projects, green building regulations and standards are set as a holistic framework that guides the design team towards reducing and making resource consumption efficient. i.e., water, energy, and other natural resources, all while contributing to the mitigation of environmental pollution.

Corporate social responsibility (CSR) has been another venue for private corporations to tackle community engagement and sustainable development. Regional CSR programs have integrated sustainability concepts to give back to the community they are operating, and those initiatives include health & safety, education, eco-friendly solutions, and community investments (Issa & Al Abbar, 2015).

These efforts are inhibited by natural and operational challenges that the region is forced to face. Some of the barriers faced are scarcity of water, lack of awareness and knowledge in sustainability and environmental conservation issues (despite the high education levels), and operational challenges such as retrofitting existing buildings.

Abu Dhabi launched the Estidama Pearl Rating System (PRS) in 2010; the system adopted green building regulations for all new construction buildings and community projects (Ramani & García De Soto, 2021).



Figure 5; Principles of Estidama standards.

Dubai Green Building Regulation and Specifications (GBRS) mandated by the Dubai government on all government buildings in 2011 and new public and private constructions since 2014. The Dubai Municipality and ESMA work together to aim for an energy labelling system that reduces energy consumption by appliances and equipment (Government of Dubai, 2012).



In 2011, the Dubai Municipality and DEWA removed energy and water tariff subsidies. The tariff structure may change as an outcome of the Demand Response program, which addresses the time of use, direct load control, and load management. Consequently, the Dubai Municipality launched the Al Sa'fat rating system for commercial and residential projects in 2016 to score a buildings total energy efficiency which enhances the energy performance of the built environment, combat global warming and support the UAE's goal of Dubai Plan 2021 (GOMAA, 2017)



Shams Dubai program under executive council resolution number 46 of 2014 is an initiative launched by the Dubai Municipality illustrated in Figure 2.4 to facilitate and regulate the linking of renewable solar energy generating units on the building site to Dubai's power distribution grid. The program promotes home and commercial building owners to incorporate rooftop photovoltaic systems onsite and connect them to the national utility under a net metering mechanism.

The concept of zero energy building is vital and attractive to the UAE national agenda as it aligns with the critical priorities of the countries goal towards innovation and sustainability.

In the UAE, Abu Dhabi launched the Masdar City as a zero energy building community model project and the first in the GCC area to support the idea of development, commercialization, and adoption of renewable energy and clean energy technology systems (Tang, 2010).

3 CHAPTER 03: BUILDING-INTEGRATED PHOTOVOLTAIC FACADES

3.1 Overview

The chapter describes the selected base case study model located in Abu Dhabi, UAE, for a new building (Y Tower Adnec) under construction with typical curtain wall glazed façade systems along with the Aluminium Composite Panel Cladding in which the Aluminium composite Panel Cladding areas will be transformed into photovoltaic for the intention of achieving the concept of zero energy building. It will comprise of studying the façade technology. The general trends in the building envelope industry are studying the energy consumption of buildings with insulated glass and cladding material's building skins.

We will evaluate the projected energy consumption annually for the Building, the cost of construction, aesthetics with and without the photovoltaic cells. The study will be structured into two phases: -

1. Base Model: Building skin with Insulated Glass Units and Aluminium Composite Panel Cladding.
2. Proposition: Building skin with insulated photovoltaic glass units replacing the aesthetic energy panel.

The models will be analyzed based on design, aesthetics, thermal calculations, energy production, cost savings on energy over the long run, cost impacts on the construction phase, and durability.

3.2 Description

The commercial tower comprises three basements level + ground + 2 podium + 16 typical floors + Roof at Abu Dhabi. The project will follow ESTIDAMA two pearl rating system (Ramani & García De Soto, 2021).



Figure 6; The Y tower Adnec Building.



Figure 7; The Y tower Adnec Building.

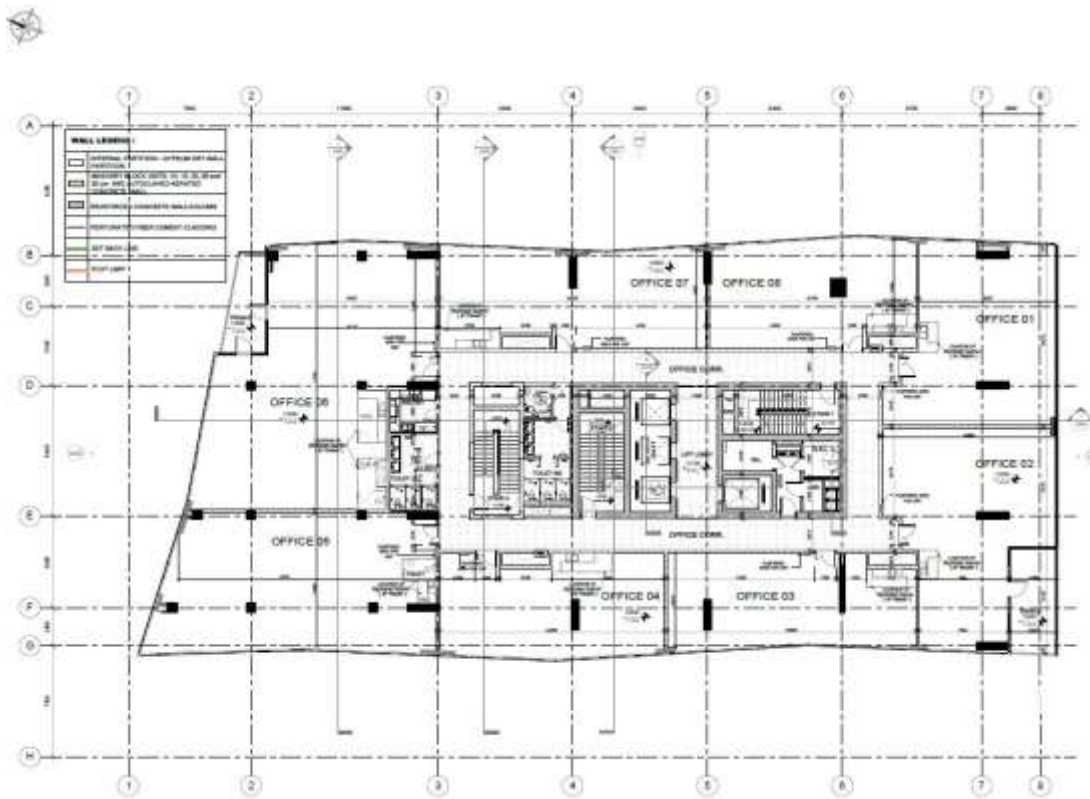

Figure 8; Floor Plan the Y tower Adnec building.

The selected base case study in Abu Dhabi will be transformed towards a net-zero energy community status by integrating photovoltaic technology on facade elements. Studying and identifying the various energy-consuming components within the base case model. Moreover, the total energy consumption and available area for photovoltaic are estimated. Finally, comparisons within multiple scenarios are performed based on the various parameters identified, such as ease of construction, aesthetics, and retail cost. This approach ensures a more targeted approach to achieve a high energy performance and efficiency for P.V. integrated into this tower.

We will analyze the tower, specification, occupancy profiles, and study parameters that impact its energy demand. Since this Building is currently under construction, the report will be based on the predicted energy consumption of this study upon the assumed data taken from similar projects. In addition, the total annual energy consumption data estimated for the remaining amenities and facilities in the selected case study community will also predict the building Energy Use Intensity (EUI) obtained from other similar types of existing buildings in Abu Dhabi and the load calculations done for the Building.

3.3 Orientation of Base Case Model

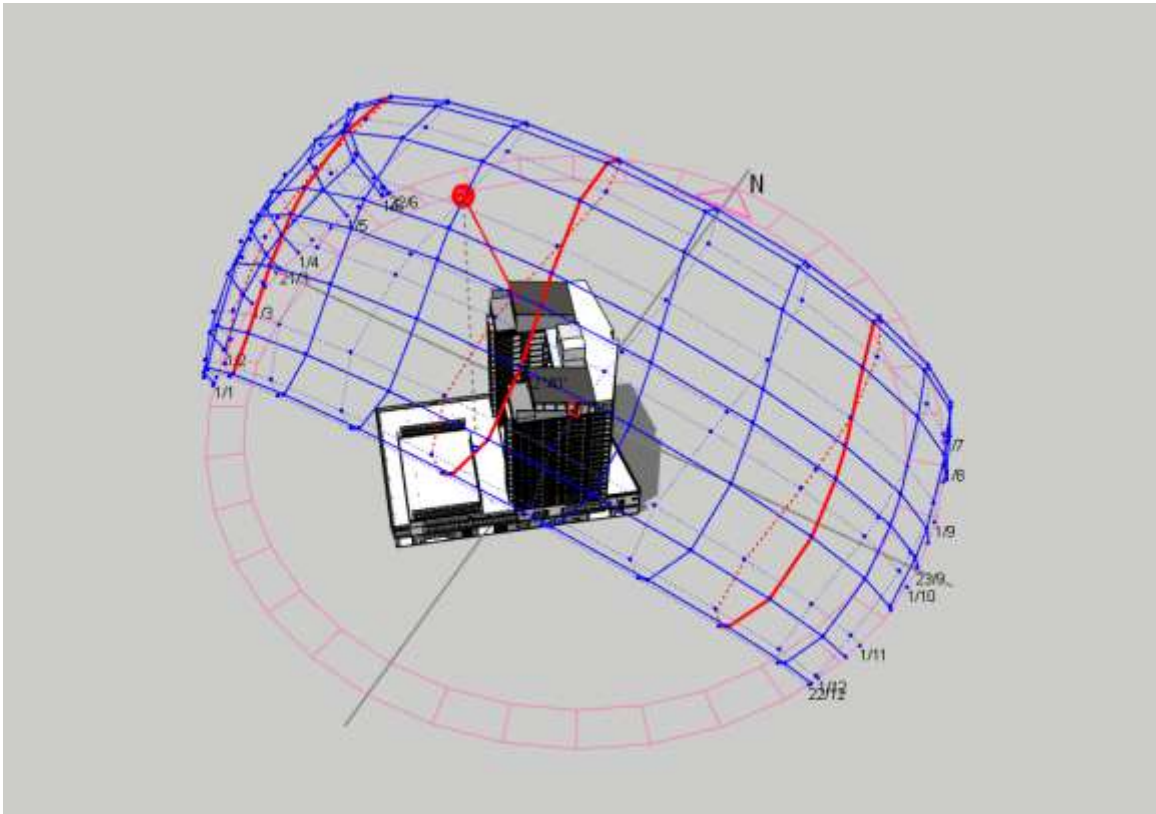

Figure 9; The Y Tower Adnec building sun path analysis. (Source; Curic Sun Path Analysis-SketchUp extension).

The orientation of the Building affects its energy demands because it varies from how much influence and effect on other factors like incident radiation, wind exposure, etc. (Heinstein & Ballif, 2013). For example, having a window designed and placed facing west will result in more solar gains and exposure, especially in the afternoon. Exposure to sunlight energy will be more significant in summer than during winters because of more sun exposure. On the other hand, the same window opening facing the South will have more solar gains in winter than during the summer due to solar zenith angle, although solar radiation intensity is more significant in summer than in winter (Ruiz & Bandera, 2014).

(Ruiz & Bandera, 2014) have highlighted that building orientation is decided and influence by factors like views, topography, prevailing winds, housing layouts, and nearby buildings, etc. In other cases, urban planning depends on older planning, road existing layout, ease of execution, road camber, etc.

Unfortunately, sometimes the design of buildings does not consider the energy savings of this energy-efficient factor (orientation). For example, considering prevailing winds to design building layout to make cross ventilation or rotate the Building to have solar gains in winter, restricted by the above reasons (Ruiz & Bandera, 2014).

Nowadays, the new simulation programs easily and quickly influence these factors in building energy demands. Moreover, today, fundamental design tools show us energy behaviours that are not obvious after comparative analysis.

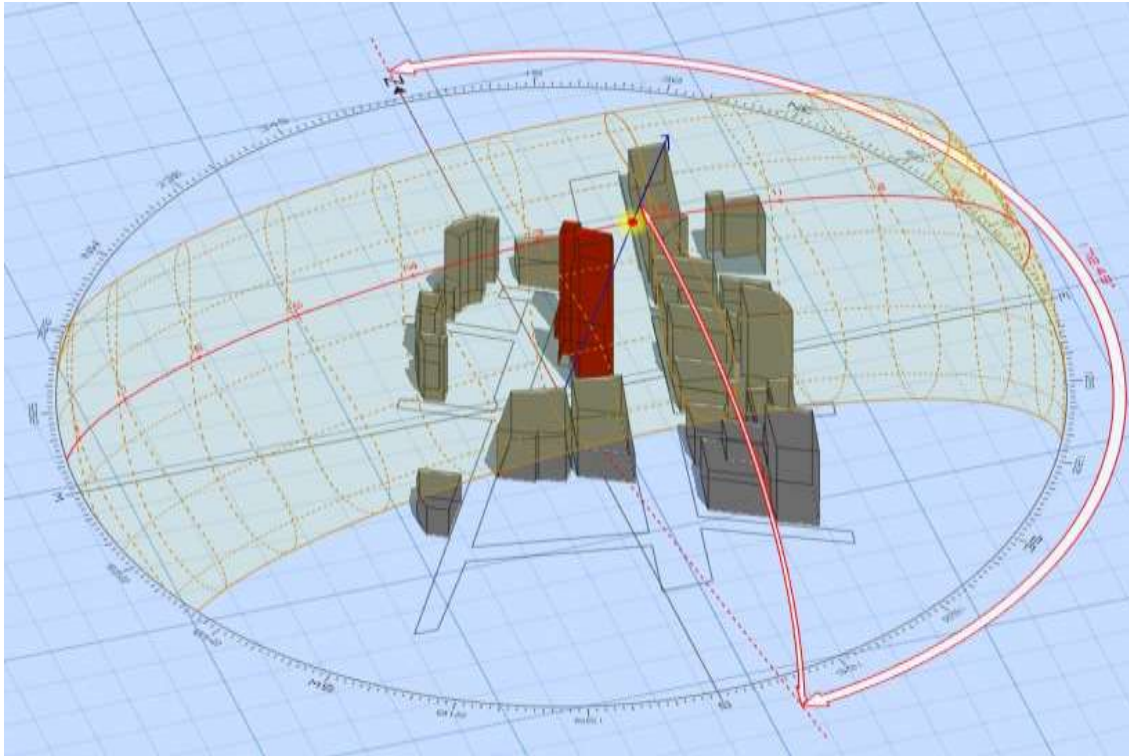

Figure 10; SUN PATH DIAGRAM Invalid source specified.

3.4 Façade Characteristics (Base Model Design)

Stick system curtain wall with one side capped 125x 60mm mullions (reinforced where necessary*) & transoms with 125 X 60mm member is used with silicone joints from outside. The stick system is a fully four-way structural glazed system. Highly thermally insulated self-supporting aluminium façade system is used along with 32mm insulated double glazed units.

The basic specification's for the façade system to comply with:-

- **Loading Requirements and Loading Strategy**

When assessing loads, basic assumptions:

Dead loads, including loads due to fixtures and fittings, act concurrently (unless stated otherwise below) with all live loads (as defined within this specification). All live loads shall be considered, including wind, barrier, and thermal climatic.

Partial factors and combination factors shall be under the appropriate EN Standard.

Worst caseload directions shall always be utilized (i.e., live loads shall act in the same direction).

- **Dead Loads**

The envelopes (vertical or sloped) own dead load shall be accommodated locally without causing deflections or movements that will affect infill panels and glass.

Permanent fixtures apply the dead load, glazing/ ACP cladding, or services secured to internal, external, or reveal surfaces.

- **Live Loads**

Wind Loads

Loads shall be calculated based on a return period of 1 in the 50-year probability of occurrence.

Calculation methods following the ASCE (Association Society of Civil Engineers); document 7-05: 'Minimum Design Loads for Buildings and Other Structures' shall be accepted. The minimum essential wind speed shall be 45m/s.

The works shall be designed to resist the different pressure and suction wind loads acting on the other areas of the Building. These shall take into full consideration the internal and external pressure coefficients. Particular attention shall be given to the shape of the Building, and also external turbulent wind flows around corners, parapets, and edge conditions. When assessing internal pressure coefficients, considering those associated with dominant openings within the Building.

The wind loads utilized shall be appropriate for façade elements with a diagonal dimension no greater than 5m. Wind tunnel testing shall be undertaken where data to establish wind loads on the Building is not available.

- **Air Leakage**

The air leakage rate through the works shall not exceed when measured per the procedure contained in section 3.0 of this specification (ASTM standards).

Pressure Difference	Air Leak Rate	
	Infiltration	Exfiltration
300 Pa	1.09 m ³ /h/m ²	1.09 m ³ /h/m ²

- **Water Penetration Resistance**

A minimum of two lines of weather defence shall be utilized. Cavities between the primary (outer) defence and the secondary (inner) defence (and any other line of defence) shall be drained and ventilated to the exterior.

Where systems incorporate gasket seals, additional 'wet applied' seals over these gaskets reinforce the weather resistance. Typical examples include applying a seal between the edge of a pressure plate, cap, or bead and an infill panel within a dry glazed system.

Properly designed and installed 'wet seals' may be utilized as a first-line (primary) of weather defence, providing that a secondary line of weather defence exists behind this outer seal which will drain water to the external.

When tested per section 3.0 of this specification, up to a maximum test pressure as prescribed below for each element, there shall be no water leakage:-

- Onto the internal face of the facade at any time during the test
- Into those parts of the façade that are not designed to be wet would negatively affect the material due to water presence, resulting in rusting or short-circuiting.

For,

Element	Peak pressure (PSF)	Peak pressure (Pa)
Curtain walling	15	718Pa

- **Glass Description**

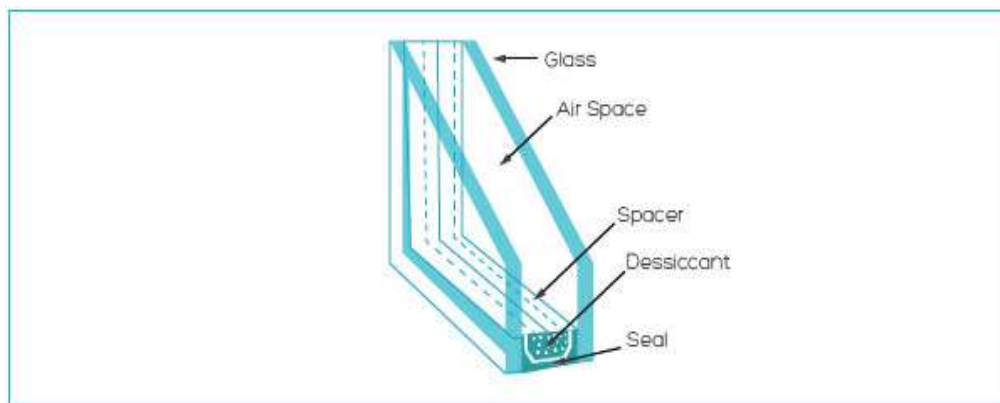

Figure 11; Double glazed glass.

The glass proposed for the project is a 32mm thick Double Glass Unit with outer 6mm HD Grey Reflective Tempered glass + 20 mm airspace + 6 mm Guardian Sunt T Low E tempered glass. The performance value of the glass will be equivalent to:-

Table 2; Aspects of DGU glass. Source; KMM Group.



PERFORMANCE CALCULATOR

Neutral Grey option

		Outdoors		Indoors		Thermal Stress Guidance (COG) (°C)
GLASS 1	Clear (Middle East) Thickness = 6mm	#1 -----	#2 Guardian HD Grey (Middle East)			
GAP 1	100% Air, 20mm (.787")					
GLASS 2	Clear (Middle East) Thickness = 6mm	#3 ClimaGuard® Sun T	#4 -----			Go 38.0
Total Unit (Nominal) = 1 1/4 in / 32 mm		Slope = 90°		Window Height = 1 meter		
Estimated Nominal Glazing Weight: 28.96 kg/m²						

Summary Data
Calculation Standard: NFRC 2010

Visible Light		Solar Energy		Other Data	
Transmittance % (τ_v)	15	Solar Heat Gain Coefficient (SHGC)	0.17	Sound Transmission Class (STC)	34
Reflectance-In % (ρ_v)	21	Shading Coefficient (sc)	0.19	Weighted Sound Reduction Index (R_w)	34
Reflectance-Out % (ρ_{ν})	13	Relative Heat Gain (RHG)	128	Outdoor Indoor Transmission Class (OITC)	29
Color Rendering Index % (R_a)	93.9	Transmittance % (τ_e)	9	Wind Speed	5.50
Light to Solar Gain (LSG)	0.90	Reflectance-In % (ρ_e)	37	Draft Speed	0
Thermal Properties		Reflectance-Out % (ρ_e)	15		
U-Value Winter Night (W/m²·K)	1.74	Absorptance % (α_e)	75		
U-Value Summer Day (W/m²·K)	1.16	Ultraviolet % (τ_{UV})	5		
R-value (m²·K/W)	0.58	Damage-weighted Transmission % (Tdw)	10		
		Thermal Stress Guidance (Center of Glass)	Stop		

Benefits of Using DGU Glass

- ✚ Cooler in summer: Double glazing insulates your area against temperature extremes, trapping some of the summer sun's rays and minimizing the heat that burns through the windows on hot sunny days.
- ✚ Reduces energy usage: There would be a need for heating systems to reduce energy consumption, saving on power bills, and helps the environment.
- ✚ Reduces condensation: Condensation can be a severe problem, particularly in older homes, as it causes mould and mildew, and in some cases, it will also rot timber window frames and damage people's health. Double glazing works to help in the reduction of excess moisture on the window panes.

- ✚ Reduces noise: Double glazing reduces noise for a calmer and quieter home. High-performance double glazing can reduce outside noise by up to 60%, making it a significant investment if the proposed project is on a busy road or beneath a flight path.
- ✚ Enhances resale value of buildings and properties: Double glazing is an excellent way to increase the resale value. With double glazing, old housing stock can be made desirable and valuable to the purchaser seeking to acquire an efficiently insulated building. Existing Building and housing stock can also be retrofitted and renovated using double-glazing, thus the material's numerous benefits.
- ✚ Helps reduce interior fading: direct U.V. light usually results in bleaching and dyes used on drapes, carpet, and furniture (particular glass types required). Double glazed glass has components that reduce the amount and intensity of transmission of U.V. radiation. This means there is no need to set up thermal drapes, which leads to the obstruction and blocking of exterior view and reduces natural lighting.
- ✚ Increases security: Double glazed glass is toughened and reinforced to ensure safe and resistant breakage, reducing the chances of intruders breaking into one's property.

- **Thermal performance of proposed façade envelope**

Code & Standard used for calculation of the thermal Value of the panel is

EN ISO 102631: Thermal Performance of curtain walling-calculation of thermal transmittance

The following climate conditions are used for the determination of the U-Factor:

Summer Simulation Conditions:

Exterior 46oC dB/ 29oC wb

Interior 24.0oC/RH 50% +/-5%

The total U-Value of the unit using the "Area Weighted" method

Formula Used:

$$U_{cw} = (U_g \times A_g + U_f \times A_f + \Psi_{spacer} \times L_{ge}) / A_{cw}$$

U_{cw} = Total Product U-Value (W/M²k)

U_g = U Value at the center of infill- glass vision & non vision (W/m²K)

A_g = Area Infill-glass vision & non vision (m^2)

U_f = U Value of the aluminium frame (W/m^2K)

A_f = Area of the aluminum frame exposed (m^2)

Ψ_{ge} = Linear thermal transmission of the edge of the glass (W/mK)

L_{ge} = Distance of linear circumference of the edges of the glass (m)

A_w = Total Product Area

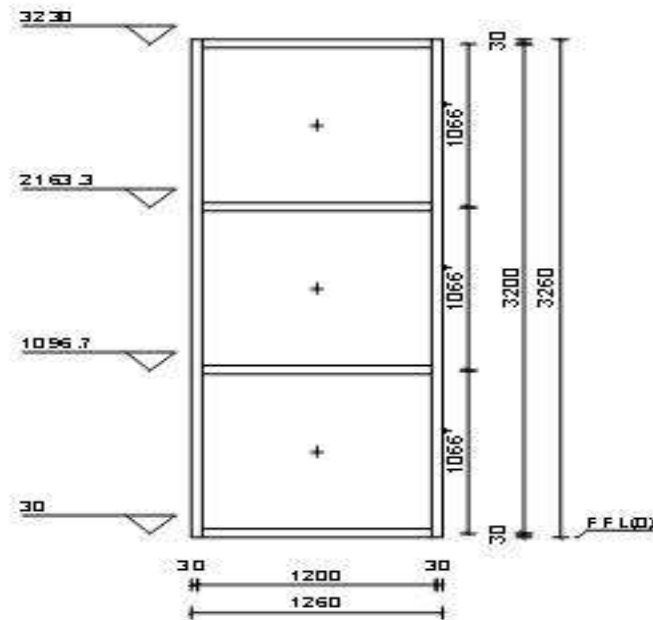

Figure 12; U-Value weighting in building floors.

The U- Value for the aluminum cladding and the glass panels has been calculator using the Estidama Pearl Building Standarads;

Glass U value 1.56 W/m²K

ACP Panel U value 1.1 W/m²K

Heat Loss 1.804 m². K/W

3.5 Photovoltaic Systems

Solar Energy is delivered to Earth mainly in two forms:-

1. Heat
2. Light

There also happens to be two major types of solar power systems;

- A. Solar thermal systems that are used to trap heat are used to warm water in buildings.
- B. Solar P.V. systems are used in harnessing and convert solar energy which is converted to electricity.

Our research focuses on energy production by using photovoltaic panels to study the depth of the photovoltaic panels.



Solar P.V. systems generate direct current (D.C.), which most building appliances and systems are unusable. This necessitates the conversion of the energy to alternating current (A.C.) by using an electric inverter. The electric energy in the form of A.C. is then fed to the Building's A.C. distribution boards ("ACDB") (David Tan, 2011).

Further, the photovoltaic systems can be categorized into two methods:-

- i. Grid-connected solar P.V. systems
- ii. Off-Grid Solar P.V. systems
- iii. Grid-connected solar P.V. systems.

(Sreedevi, et al., 2017) have indicated that the power generated in a grid-connected P.V. system is uploaded to the supply grid for transmission, distribution, and consumption. Solar grids ease the burden and reliance on other sources like the burning of carbon fuels. Grid-connected PV systems

worldwide account for about 99% of the installed capacity compared to stand-alone systems, which use batteries. Battery-less grid-connected P.V. is cost-effective and requires less maintenance. Batteries are not needed for grid-connected P.V. Most solar P.V. systems are usually installed on buildings or the ground, especially where land and space are not an issue of concern (David Tan, 2011).

Solar P.V. systems used on buildings can either be placed on the roof, the most common type of solar installation, or mounted and integrated with walls. The integration of solar P.V. systems with structural elements of the building, e.g., wall facades, is called Building Integrated Photovoltaic ("BIPV"). The integrated solar P.V. system is usually used in place or together with various construction elements and materials like walls, roofs, window glass, thereby enhancing the cost-benefit of using the materials due to their duality of purpose (Attoye, et al., 2017).

A building has two parallel power supplies: the solar P.V. system and the general power grid. The combined power is fed to all the loads connected to the main ACDB (Nath Shukla & Khare, 2014).

The total amount of electrical energy generated and exported to the main power grid depends on the scale and efficiency of the solar P.V. system and the energy requirements of the Building. To ensure that all the power is utilized efficiently, excess power generated from the Building is fed to the primary power grid (David Tan, 2011). If the energy generated by the solar P.V. system is insufficient for the Building's energy needs, additional power will be channelled from the primary power grid (Nath Shukla & Khare, 2014).

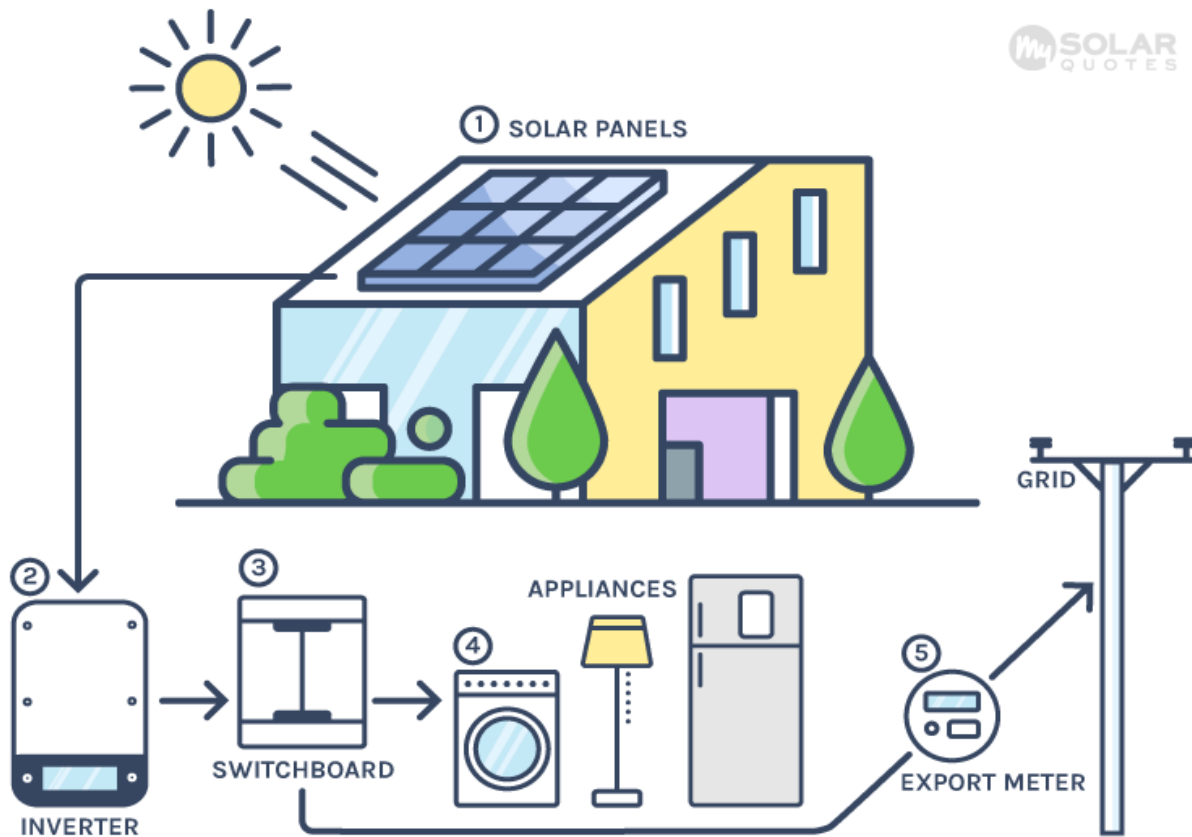
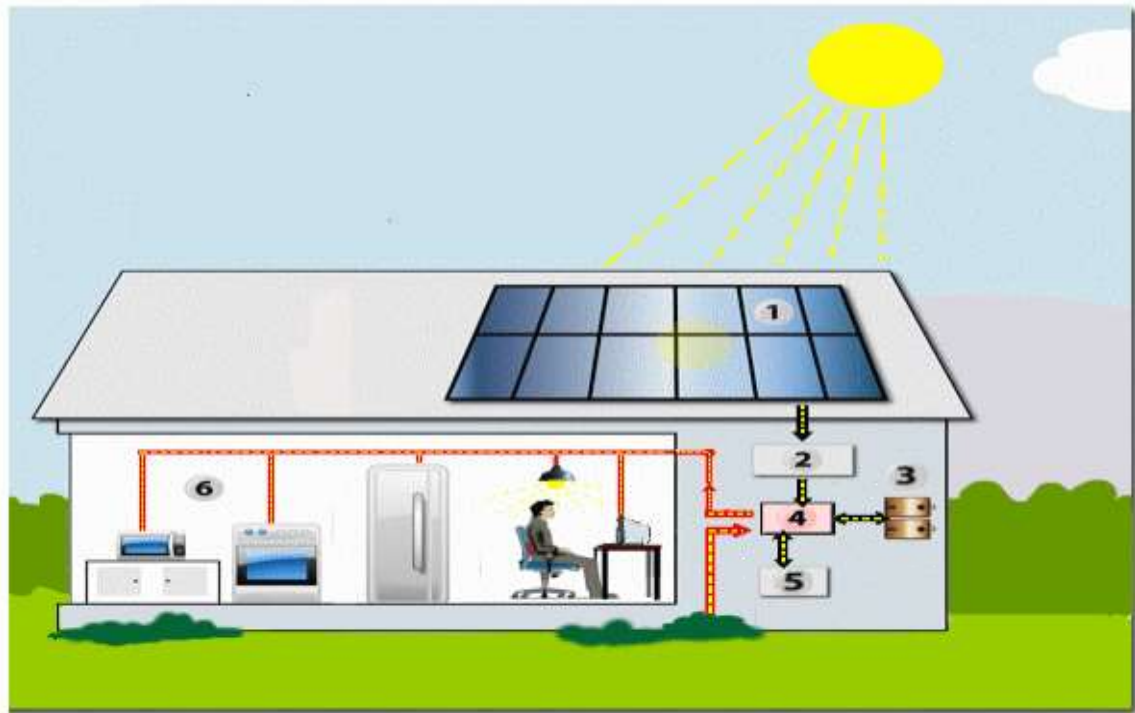

Figure 13; Schematic representation of the possible uses of solar harnessed electricity.

i. Off-grid-connected solar P.V. systems

(Mohanty, et al., 2016) highlights that off-grid solar P.V. systems are ideal, cheap, and sustainable means of providing electricity, especially in areas without a power grid. Such solar P.V. systems are helpful for isolated sites and communities where access to the power grid is far away, for example, in rural areas or off-shore islands where supplying grid energy would be expensive. However, it is also possible to set up and install a solar mini-grid as a measure to combat inconvenient energy sources and supply, environmental degradation as well as the high cost of accessing within the city in situations where it is inconvenient or too costly to tap electricity from the power grid (David Tan, 2011).

Batteries happen to be a crucial component of all off-grid solar P.V. systems. Rechargeable batteries such as lithium-ion, lead-acid, nickel-cadmium, or lithium-ion batteries are used to store electricity for use under conditions with little to no output from the solar P.V. system during winter (David Tan, 2011).



1. Solar Modules **4. Solar UPS Controller**
2. Charge Controller **5. Inverter**
3. Batteries **6. Appliances**

Figure 14; Components of a home solar mini-grid.

Technology

According to (David Tan, 2011), photovoltaic cells are made of light-sensitive semiconductor materials which use photons to dislodge charged electrons to drive an electric current. There are two main categories of technology used for P.V. cells, namely:-

1. Crystalline silicon, which accounts for the majority of P.V. cell production
2. Thin film, which is newer innovation and happens to be growing in popularity.



Mono-Crystalline Silicon PV Cell

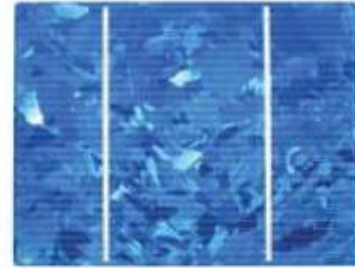

Poly-Crystalline Silicon PV Cell

Figure 15; Mono-Crystalline Silicon PV Cell and Poly-Crystalline Silicon PV Cell.

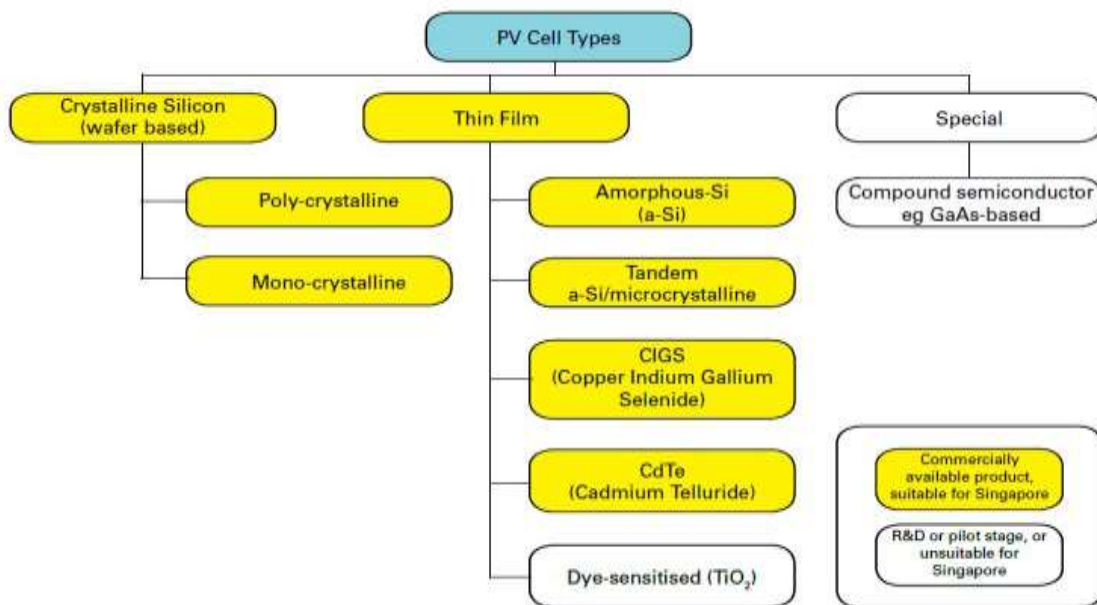

Figure 16; Tree diagram showing various types of PV cells.

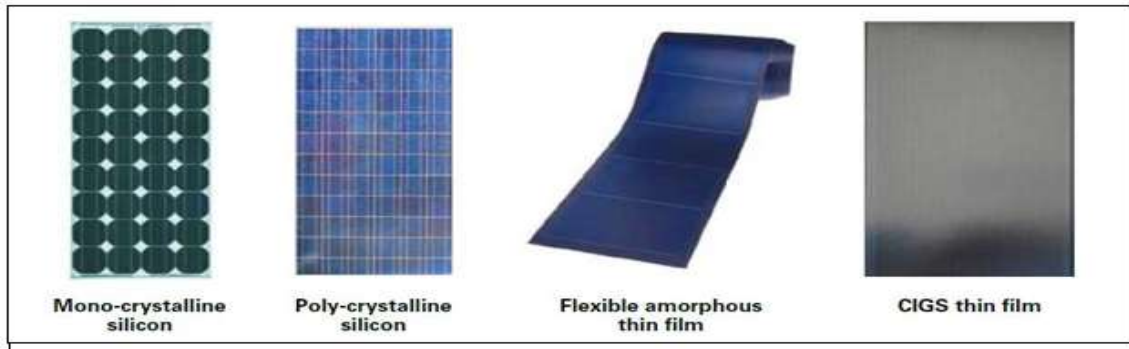

Figure 17; Types of PV cells.

The different modules of PV cell modules have different characteristics and capabilities. This is owed to the different rates of reaction of the chemical composition of the PV cells. Mono-crystalline silicon PV cells have the highest efficiency rates ranging between 12.5%-15%, poly-crystalline Silicon 11%-14%, copper indium gallium selenite 10%-13%, cadmium telluride 9%-12%, and amorphous silicon 5%-7%.

Table 3; Conversion efficiency in different PV modules.

CONVERSION EFFICIENCY OF VARIOUS PV MODULES TECHNIQUE'S	
TECHNOLOGY	MODULE EFFICIENCY
Mono-Crystalline Silicone	12.5 %– 15%
Poly Crystalline Silicone	11-14 %
Copper Indium Gallium Selenite (CIGS)	10-13%
Cadmium Telluride (CdTe)	9-12%
Amorphous Silicon (a-Si)	5-7%

3.6 SOLAR PV SYSTEMS ON BUILDINGS

PV integrated materials represent one approach that had yield breakthroughs and will grow in the coming years.

After the commercialization of photovoltaic (P.V.) panels, Architects, Engineers, and builders have sought creative methods to integrate aesthetically. V.s into buildings through either P.V. embedded materials or architectural composition strategies (Heinstein & Ballif, 2013).



Figure 18; Typical Solar Aesthetic Panel.

Standard PV panels are better understood and preferred, yet they introduce aesthetic, construction, and regulatory challenges. Neighbourhood arrangements often prohibit solar for aesthetic reasons. We will evaluate the aesthetic preferences with solar and Zero Energy buildings. Recognizing that there are aesthetic solutions where P.V. can be desirable, we should devote our efforts to improving P.V.'s desirability through architectural means (Heinstein & Ballif, 2013).

In short, solar does not always look good, but with the right approach and the right design, we see it becoming more of an asset. So here we come up with the proposal of the aesthetic solar panels, which will not give any feel of the solar panels embedded in the envelop panel.

3.6.1 Functional & Constructive Aspect

The building envelope has to fulfil a broad and complex set of protection and regulation functions. Some regulations require different structures and components like fixed/mobile parts, opaque and transparent elements. For durability and applicability of the integration of solar modules in the envelope system, proper research and studies must be conducted to ensure that they are provided

in a manner that doesn't compromise the building's structure, energy efficiency, aesthetics, and stability.

To maximize the benefit from the multifunction solar elements that are taking over the envelope functions of our buildings and premises, designers, architects, engineers, and other built environment professionals need to put more effort, time, and resources into developing solar P.V. systems while still maintaining the functionality of elements of the Building like walls by mounting or restraining the use of these materials (Heinstein & Ballif, 2013).

On another perspective, it brings the significant advantages of a global cost reduction and an enhanced architectural quality of the integration (Heinstein & Ballif, 2013). However, function compatibility is essential to ensure that the new multifunctional envelope system meets the necessary building construction standards (Munari Probst & Roecker, 2012).

- ✚ The panel load should be adequately transferred to the load-bearing structure through the appropriate fixture's
- ✚ The panel should be fire & weather resistant, saving it from wear & tear.
- ✚ Resistances against wind load and impact and should be safe within permissible limits of stress and deflection.
- ✚ Risks of theft and damage related to wreckage should be evaluated, and appropriate measures are taken.
- ✚ The fixing is eyed at avoiding thermal bridges, and the overall U value of the wall should not be negatively affected
- ✚ Vapour transfer through the wall helps avoid condensation layers and moisture by allowing the wall to remain dry.

Apart from the highlighted standards of building and construction constraints, the integration of solar systems involves other issues resulting from specific solar technology attributes, i.e., the presence of a hydraulic system (for S.T.) or electric cabling (for P.V.) and the high temperatures of some modules (Munari Probst & Roecker, 2012).

- ✚ The ability of the hydraulic system of S.T. to deal with water pressure differences at the different façade levels (heights) should also be carefully studied, be safely positioned within the envelope structure, and remain accessible.
- ✚ Water leakage is an issue of great concern when setting up solar P.V. systems as it may result in short circuits and rusting of wires and other vital components of the system.
- ✚ Proper cabling and connections avoid shock hazards and short circuits and put up measures to prevent and control fire outbreaks.
- ✚ The Envelope materials used in contact with the solar modules should work and withstand high temperatures.

- ✚ Safety and health issues are among the main issues of consideration and concern for collectors within users' reach, thus avoiding cases and accidents like burning or shock hazards (ground floor, window, and balcony surrounding).
- ✚ Different materials have varying expansion and contraction characteristics depending on their composition. Therefore, all the details, jointing, and materials should have compatible thermal conductivity rates like the other envelope materials.

As seen, integrating the new function "solar collection" into the building envelope requires an understanding of where (opaque parts, transparent parts, fixed/mobile elements), how, and which collectors can be made compatible with the other envelope elements materials, and functions. Each technology or sub-technology has different implementation possibilities in different parts of the envelope.

3.6.2 Formal Aspects and Aesthetics

(Munari Probst & Roecker, 2012) Suggest that all the system characteristics that affect the appearance of a building (i.e., formal system characteristics) should be rational with the overall building design. Thus, for example, the position and dimension of the panel field have to be coherent with the architectural composition of the whole Building (Heinstein & Ballif, 2013).

- ✚ Panel visible material surface texture and colour should be compatible with the other building skin materials, colours, and textures they interact with.
- ✚ Module shape and size must be compatible with the Building's composition grid and the different dimensions of the façade elements (Munari Probst & Roecker, 2012).

The actual flexibility of solar modules, mastering all characteristics of an integrated solar thermal system in energy production and building design perspectives, is not an easy task for the engineer (Munari Probst & Roecker, 2012).

The characteristics and general output of the solar P.V. system happen to be very dependent on the efficiency, size, and technology of the installed systems, which imposes the core components of the solar modules with their particular shapes and materials. The flexibility of the design and application of solar and the ideal materials and skills increase the success rate of the GEB design and its integration. (Kayali & Alibaba, 2017) Indicate that the topic of solar modules is flexible as it is also presented in two very different fields of S.T. and P.V., making the integration design work either more or less challenging.

3.6.3 Photovoltaic System Position & Sizing

To create an effective photovoltaic façade system, the crucial part is the system position & sizing. Furthermore, the positioning & sizing of the photovoltaic system depends on many factors like:-

- ✚ Area availability on the different envelope parts.

- ✚ Seasonal solar radiation on these surfaces.
- ✚ Desired solar fraction

The solar radiation differs from the orientation; lower-exposed systems need a more extensive panel area than well-exposed ones to achieve solar fraction (Kayali & Alibaba, 2017). This also holds for technology efficiency: the higher the panel efficiency, the smaller the needed panel area.

Understanding the cross-impact of orientation and technology on system size is fundamental for a proper system choice. For example, solar thermal systems usually limit investment costs by maximizing the annual solar radiation (45° tilted, facing south for mid-latitudes), thus minimizing the needed panel area (Kayali & Alibaba, 2017). The approach happens to be quite an effective strategy, but the Building in question has to use the total energy produced by the system. But because of the summer peak production leads to solar fractions up to 50–60 % only in mid-latitude.

3.7 Façade Characteristics (Base Model Design with Photovoltaic Panels)



Figure 19; The Area of Study, Y Adnec Towers, Abu Dhabi. Source; (Author). The building existing Double Glazed glass will be replaced remodelled with ACP which have the ability to harness solar energy and save energy trough using solar energy and natural lighting to replace the need for artificial lighting and grid electricity.

"How much money will a standard curtain wall / ACP system pay back? The answer is Zero. In contrast, a photovoltaic aesthetic panel will not only insulate the Building but generate power for over 30 years, helping to decrease the requirement of non-renewable source of energy, therefore leading to sustainable future."

The total exposed Aluminium composite Panel area for our base case model is around 7265 sqm.

Type of Photovoltaic Glass: **Amorphous Photovoltaic Silicone Glass**

Amorphous silicon glass happens to offer a perfect combination of aesthetics and functionality (Schropp, et al., 2007). The solar P.V. glass displays similar mechanical properties as conventional building glass used in the construction industry. Amorphous carbon applies stringent safety standards in the construction industry similar to that applied in ordinary architectural glass. However, it also generates free and clean energy thanks to the sun (active solar properties). It can also be customized in size, colour, shape, colour, and semi-transparency levels. Moreover, the material works very well under diffuse light conditions.

3.7.1 Advantages of Amorphous solar silicone P.V. Glass:-

1. It produces more power than crystalline silicone glass when put under the same light conditions and temperatures.
2. It has a uniform appearance and surface, thus the ease of a clean and proper installation.
3. The material offers different visible light transmittance levels, up to 30%.
4. Flexibility in design since the glass can be tailored and cut to the architectural needs of the Building.

3.7.2 Natural Lighting & Selective Filters

The use of amorphous silicon glass has been proved to boost thermal performance in buildings. The material is also useful in promoting natural light inside buildings while at the same time filtering harmful U.V. radiation and Infrared (Eoreports.wixsite.com, 2021).



Figure 20; Aesthetic PV Panels.

3.7.3 Insulation Properties Amorphous silicon photovoltaic glass follows both thermal & sound insulation, which could fabricate as per requirement.

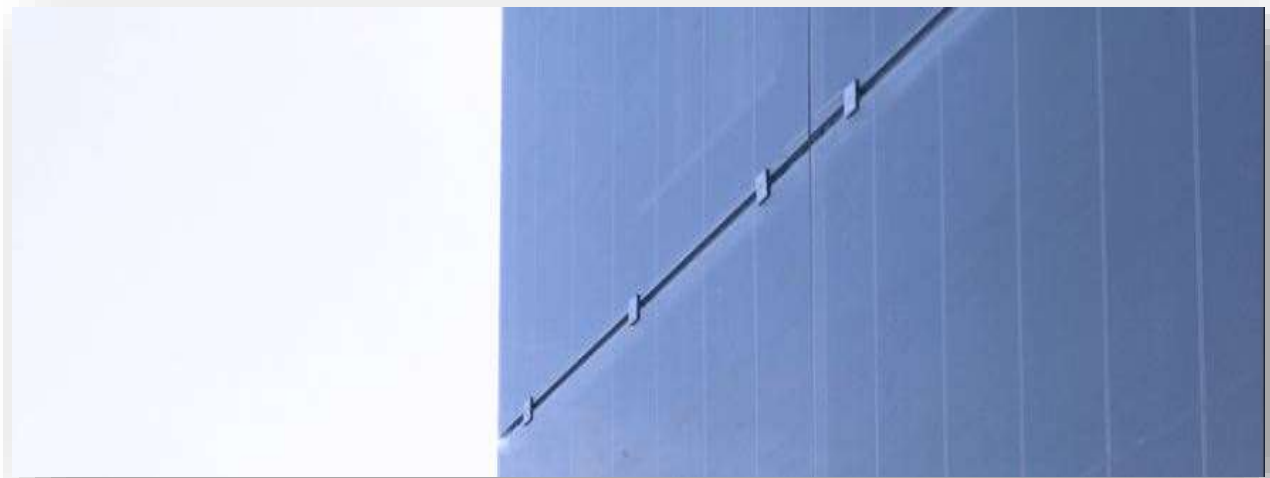

3.7.4 Standard Panel Sizes Available For Amorphous Photovoltaic Panel

Amorphous P.V. panels can be customized to adapt to the need of each project. A wide range of colour options is also possible.



Figure 21; Standard sizes available in the market for Amorphous Photovoltaic Panels

The proposed Aesthetic Energy Panels from Heliartec are made from high-efficiency non-perc monocrystalline solar cells. These cells string together with a particular circuit design structure, thereby giving maximum output. This will also reduce the shadow impacts from the surrounding buildings.

The solar layer of cells is held between the tempered glass from the outside and another tempered glass from the inside. The monocrystalline solar cells are embedded between the tempered glass panels and special laminated PVB layers to increase stability, safety, and acoustic performance. In addition, the sides and edges of the panel are sealed with special thermal materials to make the functionality and the durability of the panel resistant against moisture, air, and humidity.



Figure 22; Components of an Aesthetic Energy Panels

The panels are made with measurements in the construction industry with lengths multiples of 300 mm to maximize the wastage and utilization of the façade space to the optimum levels. The panels can be done with sizes varying from 600 mm to 3000 mm and widths varying from 600 mm to 1500 mm. The thickness of the internal and the external panels can range from 3mm thickness to up to 10mm thickness as per the customer requirements based on the wind-load calculations and other factors.

3.8 Fixing Methodology

The energy panels are installed similarly to how we fix the glass facades with the proper framing with the building structure and then apply the cementitious paints as the base coat, followed by the setting of the necessary fire barriers are to be installed on the floor wise level to meet the civil defence requirements. The glasses can be fixed either with the curtain wall mounting pattern or even with the spider glazing pattern, whichever is accepted by the client and consultant abiding with the structural calculations.

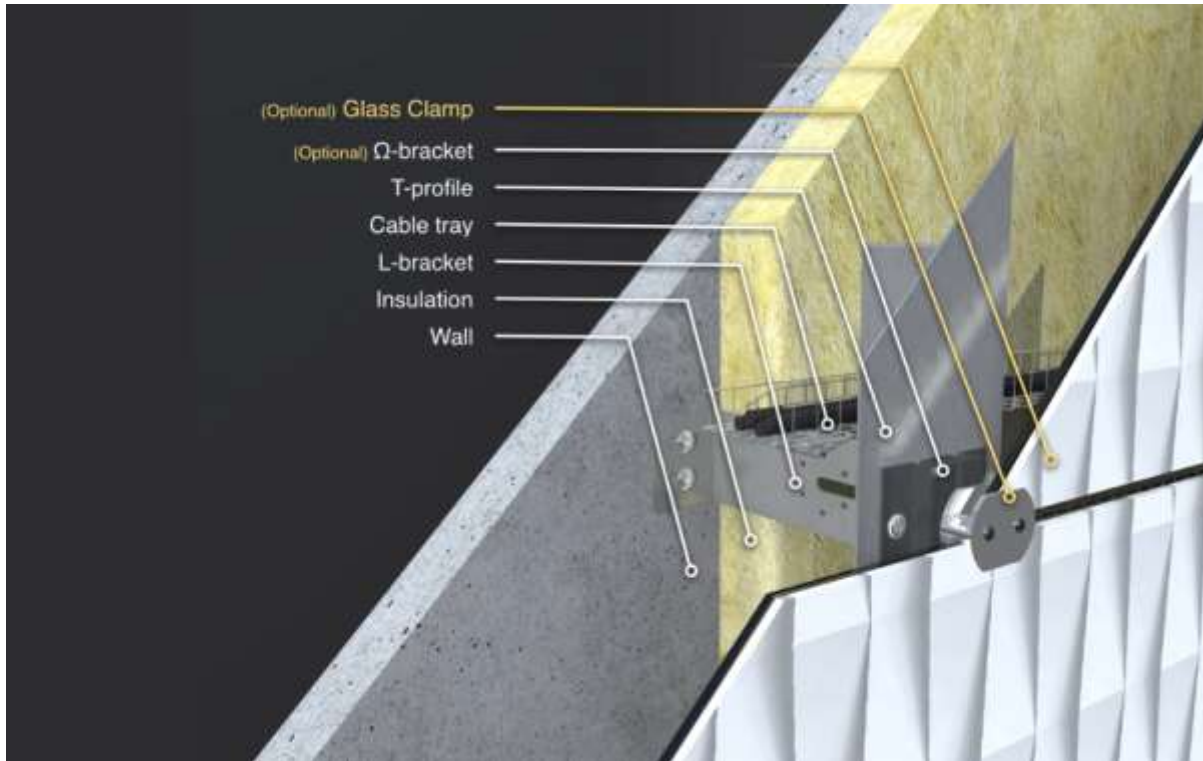

Figure 23; Installation of ACP material.

U Value Of the Aluminium Composite Panels

The glass configuration selected is equivalent to the base case model, i.e., 6mm Toughened Glass + 12mm Airspace + 6mm Toughened Glass.

The Value of the base case model glass was 1.56 W/m²K, and the proposed ACP U Value is 1.1 W/m²K.

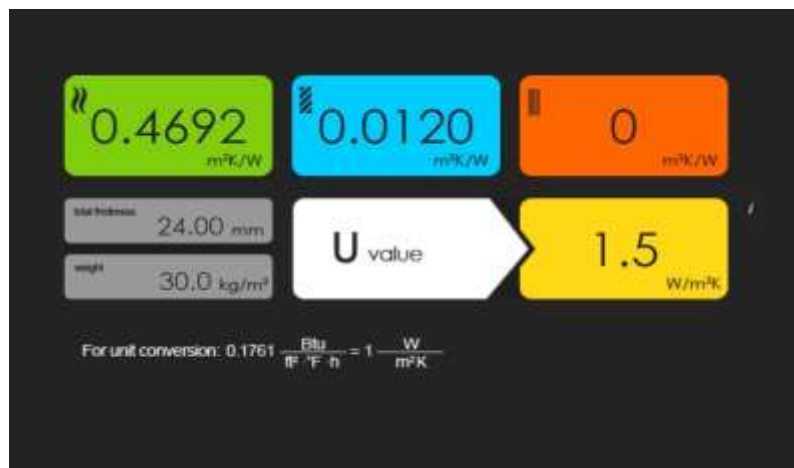

Figure 24; U value of the proposed ACP material.

3.9 General Photovoltaic Estimation

We have calculated a general estimate using a renowned photovoltaic panel supplier estimation tool, and the results were awe-inspiring with ACP material.

According to the calculations, the building will generate about 458,098 kWh of energy per year. The use of ACP also reduces the carbon footprints of the building by 302,920 Kg CO₂ annually. This was obtained after comparing the proposed energy generation model with the existing source of energy which requires the burning of about 270 barrels of oil.

If the energy produced would be used to power an electric car, it would provide enough power to drive about 3,393,251 Km.

Energy production is just estimation where factors like surrounding shadows, self-shades, or other external impacts have not been considered. This leads to a gradual reduction in energy production. In addition, other potential losses due to BOS are also excluded from these calculations. The calculation has been done using PVGIS and PVWATTS

Table 4; Calculated with energy-efficient light bulbs of 6W.

Month	E _d	E _m	H _d	H _m
January	1,051.96	32,610.81	5.28	163.79
February	1,249.25	34,978.96	6.31	176.63
March	1,185.53	36,751.43	5.98	185.41
April	1,291.10	38,733.03	6.58	197.51
May	1,420.92	44,048.55	7.32	226.82
June	1,404.68	42,140.36	7.27	217.95
July	1,355.10	42,007.98	7.03	217.91
August	1,376.49	42,671.34	7.15	221.66
September	1,353.23	40,596.99	7.01	210.16
October	1,271.70	39,422.79	6.54	202.59
November	1,106.51	33,195.29	5.62	168.72
December	997.79	30,931.37	5.02	155.52
Yearly average	1,255.36	38,174.08	6.42	195.39
Total for year	458,088.90		2,344.68	

E_d: The Average daily electricity production from the given system (kWh)

E_m: The Average monthly electricity production from the given system in(kWh)

H_d : The Average daily sun of global irradiation per square meter received by the modulus of the given system in (kWh/m²)

H_m : The Average sum of global irradiation per square meter received by the modules of the given system in (kWh/m²)

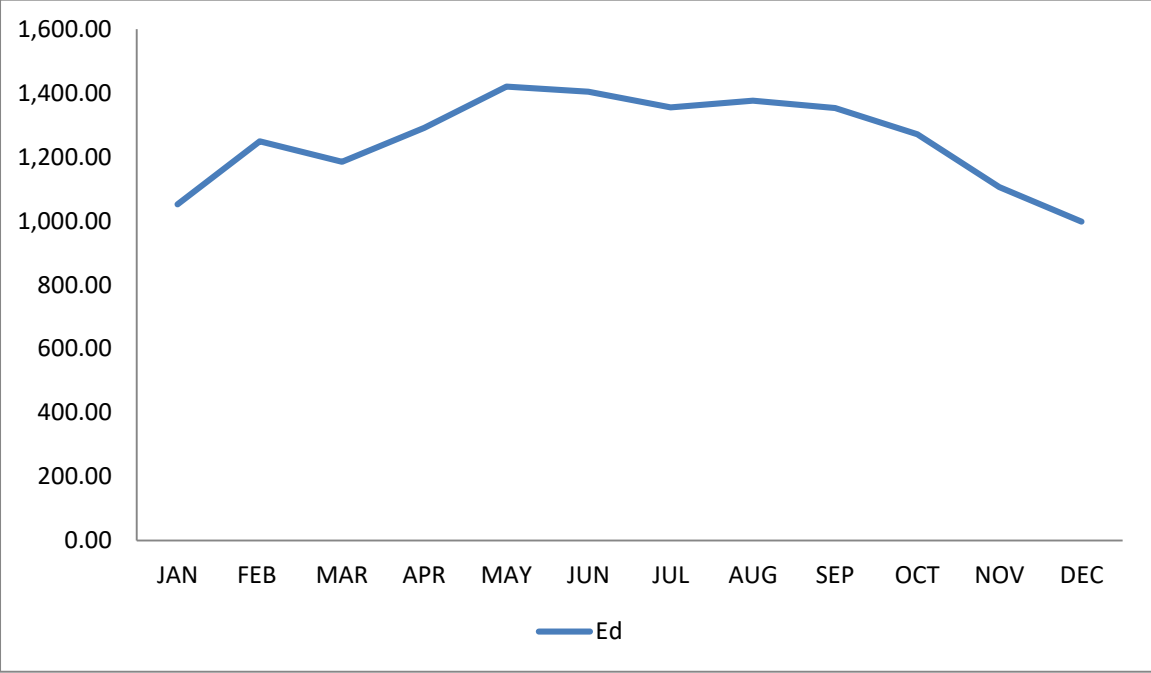

Figure 25; The Average daily electricity production from the given system (kWh).

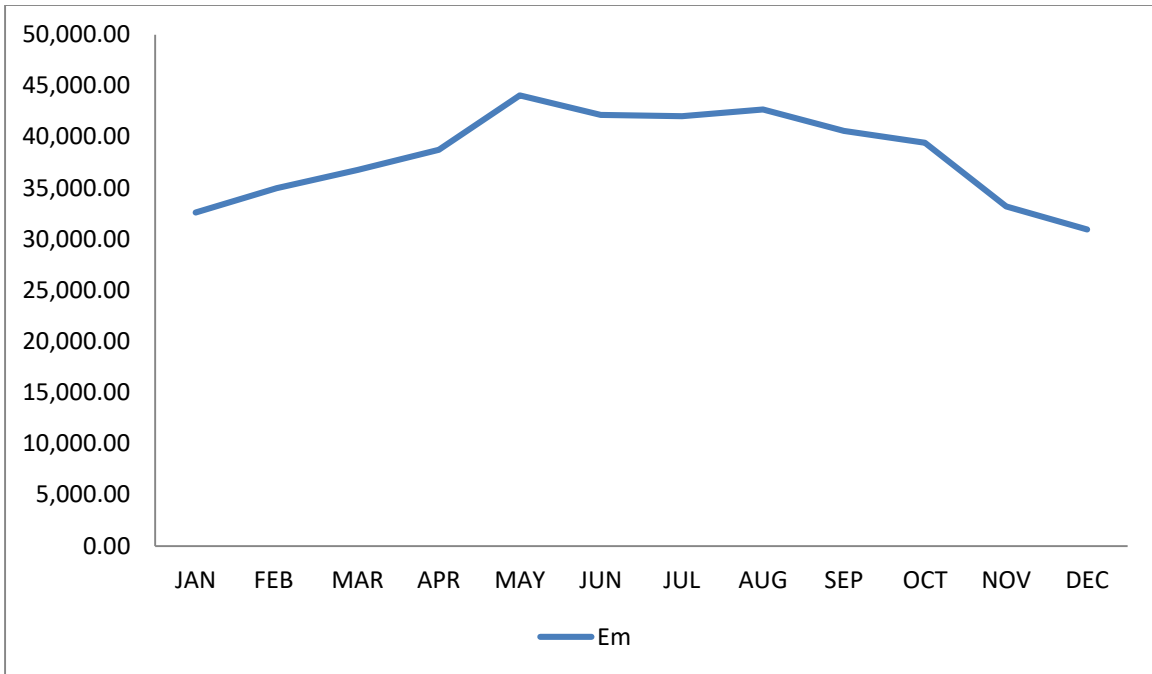

Figure 26; The Average monthly electricity production from the given system in(kWh).

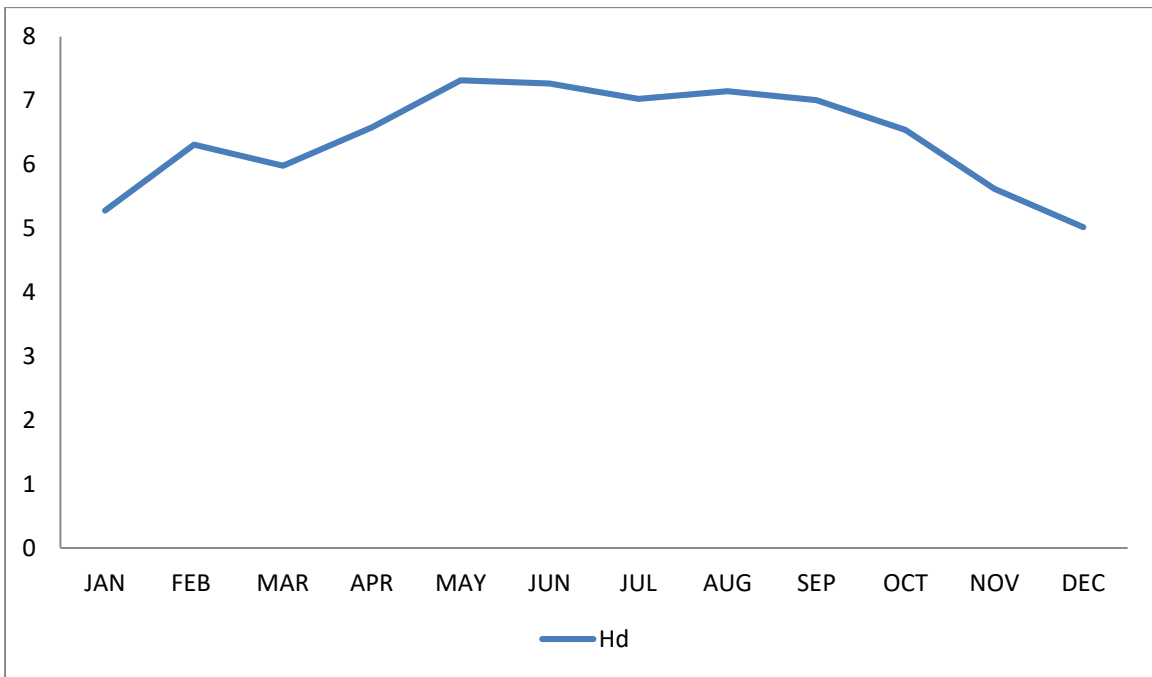

Figure 27; The Average daily sun of global irradiation per square meter received by the modulus of the given system in (kWh/m2).

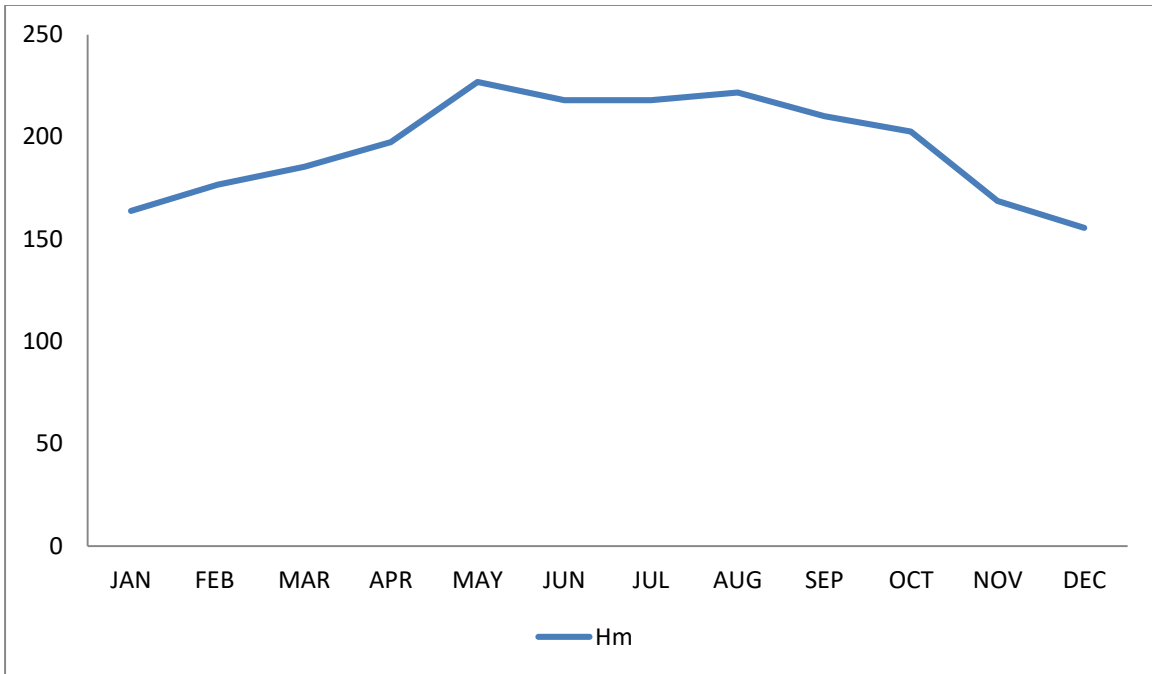

Figure 28; The Average sum of global irradiation per square meter received by the modules of the given system in (kWh/m²).

3.10 Feasibility Study

The total sun energy available for a day is equivalent to the total energy consumed for a year in the world. Therefore, if we provide a system in which the external walls of the building façade are converted to green power stations generating energy, these stations can be used for the building purpose and can even satisfy the external requirements.

Once we consider the high-rise building in the urban areas, the available space on the roofing alone will be sufficient to put up enough solar panels. But, as the building height goes up, the external wall areas are increasing, and it is an excellent opportunity to utilize such sites for power generation if possible, and it is enormous potential.

We have proposed replacing the Aluminium Composite Panels with the Building-integrated Photovoltaic system (BIPV) solution for the wall areas. This will support in generating clean energy from the sunlight available. Furthermore, we can use these areas as a large canvas on excellent masterpiece images for any unique patterns required with any design concerning the aesthetic approach.

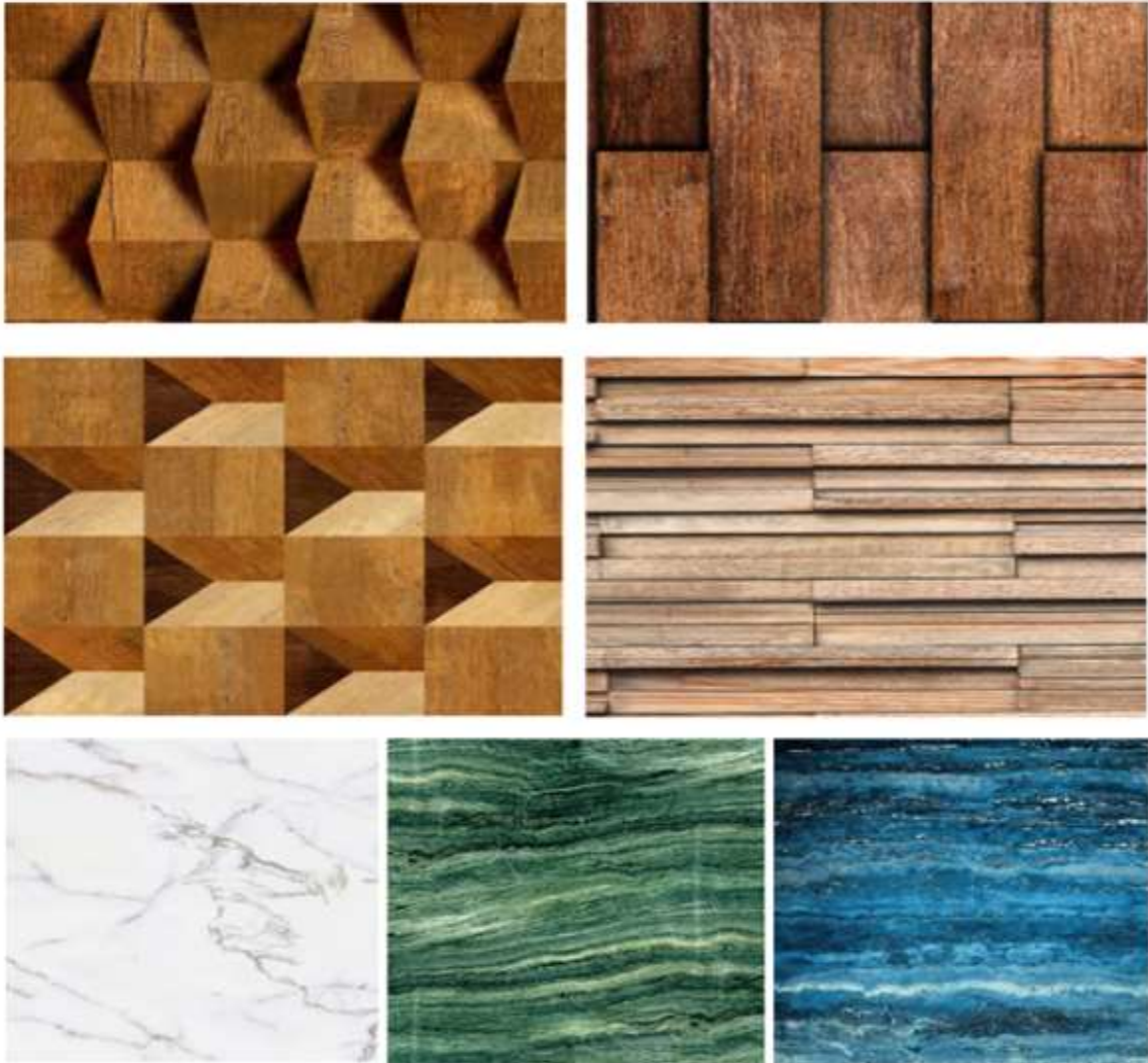

Figure 29; Aesthetic ACP material.

This document is a feasibility report of the Low-e photovoltaic glass for its integration in the four façades of 6500 SQM.

This glass generates free electricity for the Building while providing thermal and acoustical insulation, daylighting, and sun control. This combination of active and passive properties of the glass leads to an extended outstanding return on investments. The Low-E photovoltaic glass is the only architectural glass that pays for itself due to the energy savings derived from a high-performing building envelope plus the electricity generated by the glass, which is used for self-consumption. With Solar photovoltaic glass, we can benefit from having the same energy cost rate for the Building despite the increasing local electricity price, ensuring the energy cost at less than 0.04 € (0.16 AED) per kWh for the next 30 years.

The following figures and graphs reflect the average reduction in energy demand and cost per square foot of solar glass installed. This compares a conventional Insulated Glass Unit (clear glass/air chamber/clear glass) and a Photovoltaic Insulated Glass Unit, which provides a very low-risk investment with an excellent yield during the entire lifetime of the Building.



Figure 30; GEB Considerations.



ENERGY SAVINGS

ENERGY COST WITH SOLAR GLASS	(EUR/kWh)	0.04 €
Electricity cost guaranteed for the next 30 years.		
REDUCTION IN HVAC ENERGY DEMAND	(%)	39%
Maximum reduction in HVAC energy demand in this city		
AVERAGE REDUCTION OF ENERGY DEMAND	(EUR/sqm glass)	282 €
Average reduction of energy demand per square foot of Glass from energy generation and the HVAC savings in 30 years.		

Figure 31; Energy Savings with the adoption of Solar Glass.



RETURN ON INVESTMENT

IRR (30 years)	(%)	4%
Internal Rate of Return: average annual return during the first 30 years of the investment		
IRR (20 years)	(%)	1%
Internal Rate of Return: average annual return during the first 20 years of the investment.		
TIMES THE INVESTMENT (period of 30 years)	(times)	2
Number of times that the amount invested is received during the investment period of 30 years. (Average Reduction of Energy Demand /Investment)		

Figure 32; Rate of investment returns on the installation of solar glass panels.

Table 5; Total reduction in energy demand 30yrs, after adopting BIPV technologies and consequent reduction in HVAC energy use.

REDUCTION IN ENERGY DEMAND			
The energy demand of the Building in HVAC without Solar P.V. glass in 30 Years (Average increase of energy cost per year: 1.30%)		TOTAL REDUCTION OF ENERGY DEMAND in 30 YEARS	
1,796,670 €	24,152,400 kWh	Total reduction of energy demand due to the generation of PHOTOVOLTAIC ENERGY + REDUCTION IN HVAC REQUIREMENT	
GLASS CONFIGURATION	EUR	kWh	%
1. Clear glass + 12mm air chamber + clear glass	0	0	0%
2. Amorphous silicon photovoltaic glass with a transparency degree of 10% + 12mm air chamber + clear glass	695,215	9,345,681	39%
3. Amorphous silicon photovoltaic glass with a transparency degree of 10% + 12mm argon chamber + low-e glass	683,744	9,191,481	38%
4. Amorphous silicon photovoltaic glass with a transparency degree of 20% + 12mm air chamber + clear glass	673,233	9,050,143	37%
5. Amorphous silicon photovoltaic glass with a transparency degree of 20% + 12mm argon chamber + low-e glass	694,150	9,291,043	38%
6. Amorphous silicon photovoltaic glass with a transparency degree of 30% + 12mm air chamber + clear glass	593,043	7,972,204	33%
7. Amorphous silicon photovoltaic glass with a transparency degree of 30% + 12mm argon chamber + low-e glass	606,567	8,154,004	34%

Table 6; TOTAL REDUCTION IN ENERGY DEMAND (EUR)

REDUCTION IN ENERGY DEMAND		
The energy demand of the Building in HVAC without Solar P.V. glass in 30 Years (Average increase of energy cost per year: 1.30%)		Photovoltaic Energy Production
1,796,670 €	24,152,400 kWh	Amount of energy produced by Glass
GLASS CONFIGURATION	EUR	kWh
1. Clear glass + 12mm air chamber + clear glass	0	0
2. Amorphous silicon photovoltaic glass with a transparency degree of 10% + 12mm air chamber + clear glass	156,803	2,107,881
3. Amorphous silicon photovoltaic glass with a transparency degree of 10% + 12mm argon chamber + low-e glass	156,803	2,107,881
4. Amorphous silicon photovoltaic glass with a transparency degree of 20% + 12mm air chamber + clear glass	135,421	1,820,443
5. Amorphous silicon photovoltaic glass with a transparency degree of 20% + 12mm argon chamber + low-e glass	135,421	1,820,443
6. Amorphous silicon photovoltaic glass with a transparency degree of 30% + 12mm air chamber + clear glass	114,038	1,533,004

Table 7; TOTAL REDUCTION IN ENERGY DEMAND (EUR)

REDUCTION IN ENERGY DEMAND		
The energy demand of the Building in HVAC without Solar P.V. glass in 30 Years (Average increase of energy cost per year: 1.30%)		Energy Savings Induced By Thermal Envelope IN 30 Years
1,796,670 €	24,152,400 kWh	Amount of energy glass saves
GLASS CONFIGURATION	EUR	kWh
1. Clear glass + 12mm air chamber + clear glass	0	0
2. Amorphous silicon photovoltaic glass with a transparency degree of 10% + 12mm air chamber + clear glass	538,412	7,237,800
3. Amorphous silicon photovoltaic glass with a transparency degree of 10% + 12mm argon chamber + low-e glass	526,941	7,083,600
4. Amorphous silicon photovoltaic glass with a transparency degree of 20% + 12mm air chamber + clear glass	537,809	7,229,700
5. Amorphous silicon photovoltaic glass with a transparency degree of 20% + 12mm argon chamber + low-e glass	555,730	7,470,600
6. Amorphous silicon photovoltaic glass with a transparency degree of 30% + 12mm air chamber + clear glass	479,005	6,439,200
7. Amorphous silicon photovoltaic glass with a transparency degree of 30% + 12mm argon chamber + low-e glass	492,529	6,621,000

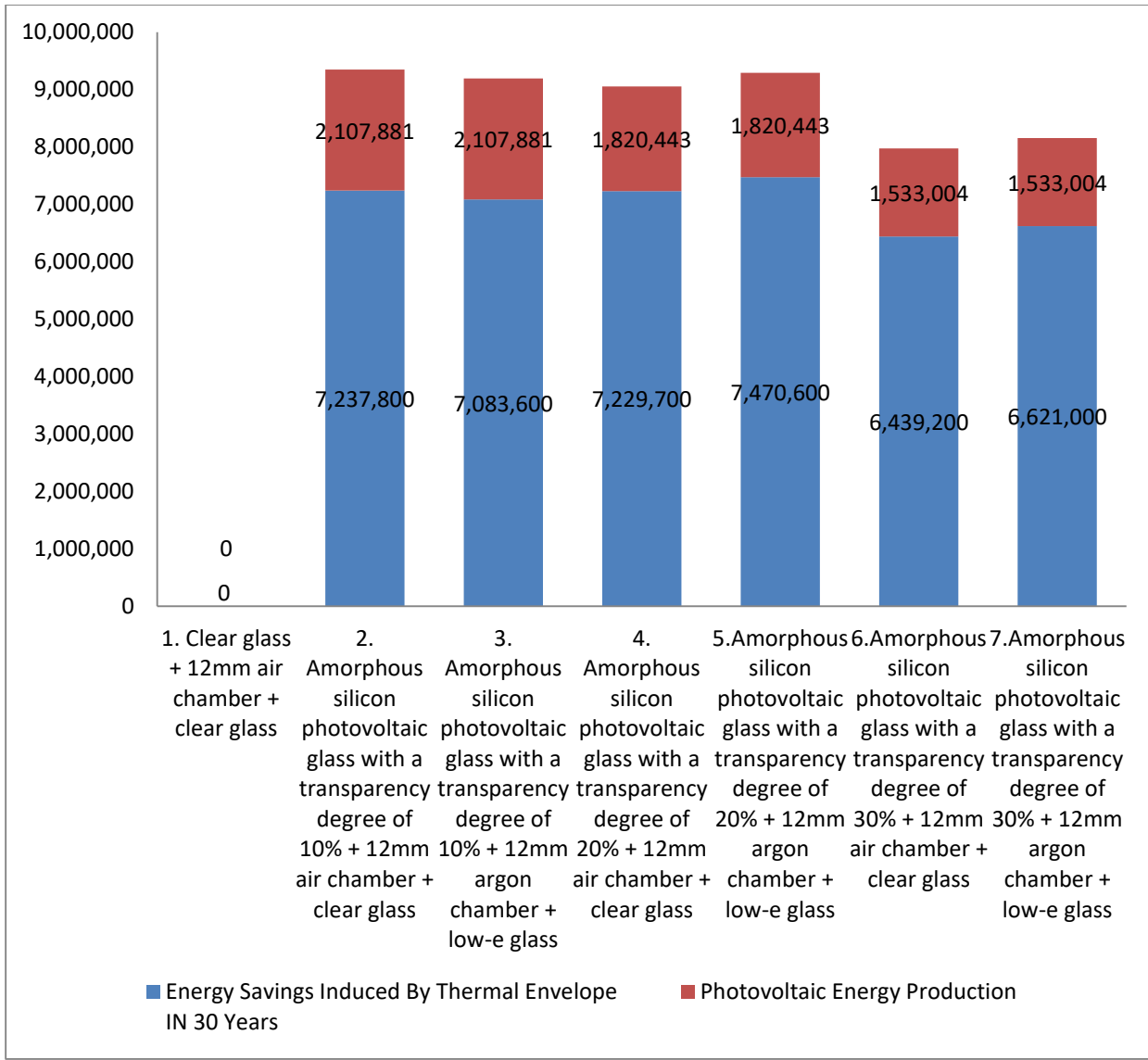

Figure 33; Energy Reduction graphs within 30yrs of adopting ACP Panels and PV Panels.

REDUCTION IN HVAC DEMAND

■ REDUCTION IN HVAC DEMAND

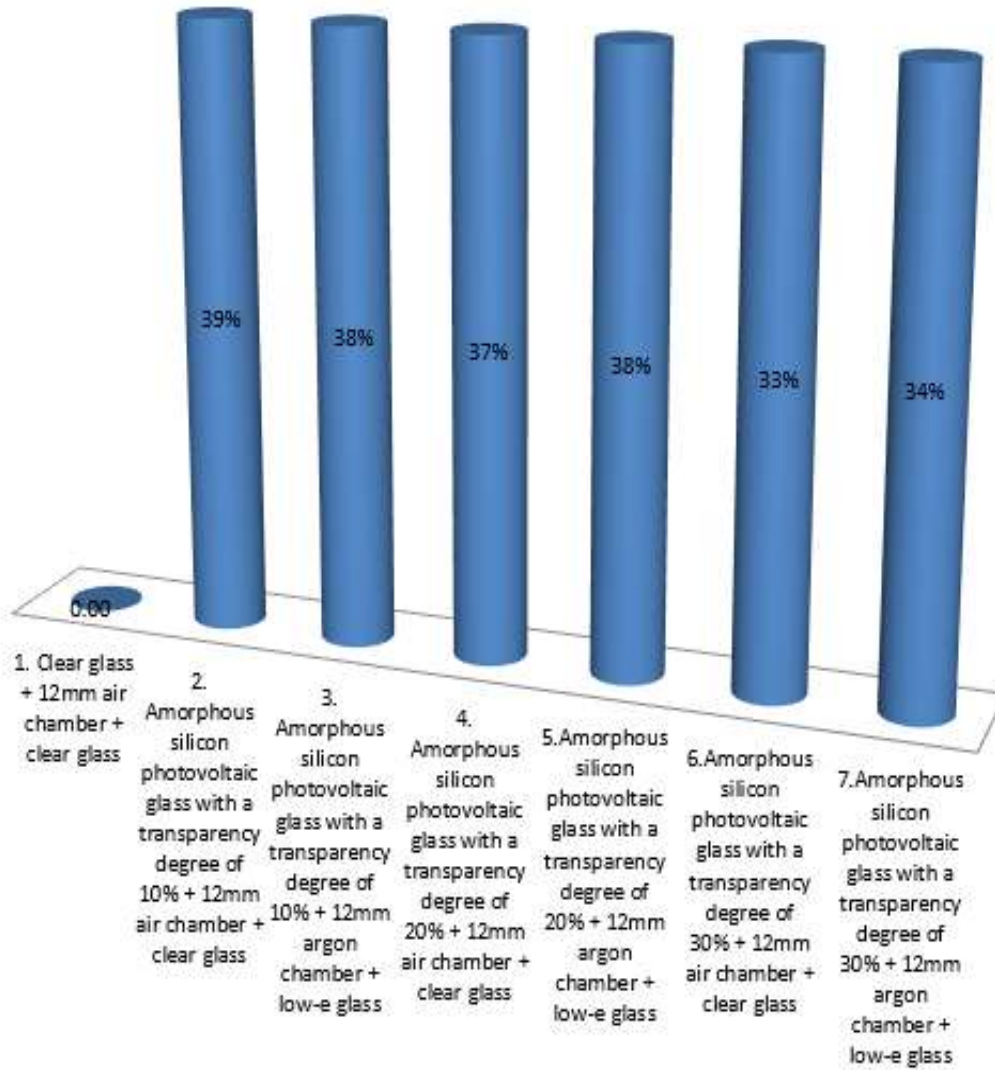

Figure 34; Reduction in HVAC Demand.

TOTAL REDCUCTION IN ENERGTY DEMAND



9,345,681 Kwh

TOTAL LIGHTNING POINTS OPERATING 4 HOURS PER DAY



17,781 Lights/ Year

AVOIDED CO₂ EMISSIONS



6,261,606 kg CO₂

BARRELS OF OILED SAVED



5,514 Barrels

BARRELS OF OILED SAVED



69,227,197 Km

Table 8; Energy Cost Per kWh.

ENERGY COST PER kWh			
GLASS CONFIGURATION	TOTAL REDUCTION OF ENERGY DEMAND in 30 YEARS		
	Electricity cost for the next 30 years (Amount to invest / Total reduction of energy demand	Local Electricity Cost	Savings in the electricity expense generated from a reduction in electricity cost %
	EUR/kWh	EUR/kWh	%
1. Clear glass + 12mm air chamber + clear glass	Without Solar Glass are no savings in energy cost		
2. Amorphous silicon photovoltaic glass with a transparency degree of 10% + 12mm air chamber + clear glass	0.04 €	0.06 €	38%
3. Amorphous silicon photovoltaic glass with a transparency degree of 10% + 12mm argon chamber + low-e glass	0.04 €	0.06 €	32%
4. Amorphous silicon photovoltaic glass with a transparency degree of 20% + 12mm air chamber + clear glass	0.04 €	0.06 €	37%
5. Amorphous silicon photovoltaic glass with a transparency degree of 20% + 12mm argon chamber + low-e glass	0.04 €	0.06 €	33%
6. Amorphous silicon photovoltaic glass with a transparency degree of 30% + 12mm air chamber + clear glass	0.04 €	0.06 €	28%
7. Amorphous silicon photovoltaic glass with a transparency degree of 30% + 12mm argon chamber + low-e glass	0.05 €	0.06 €	23%

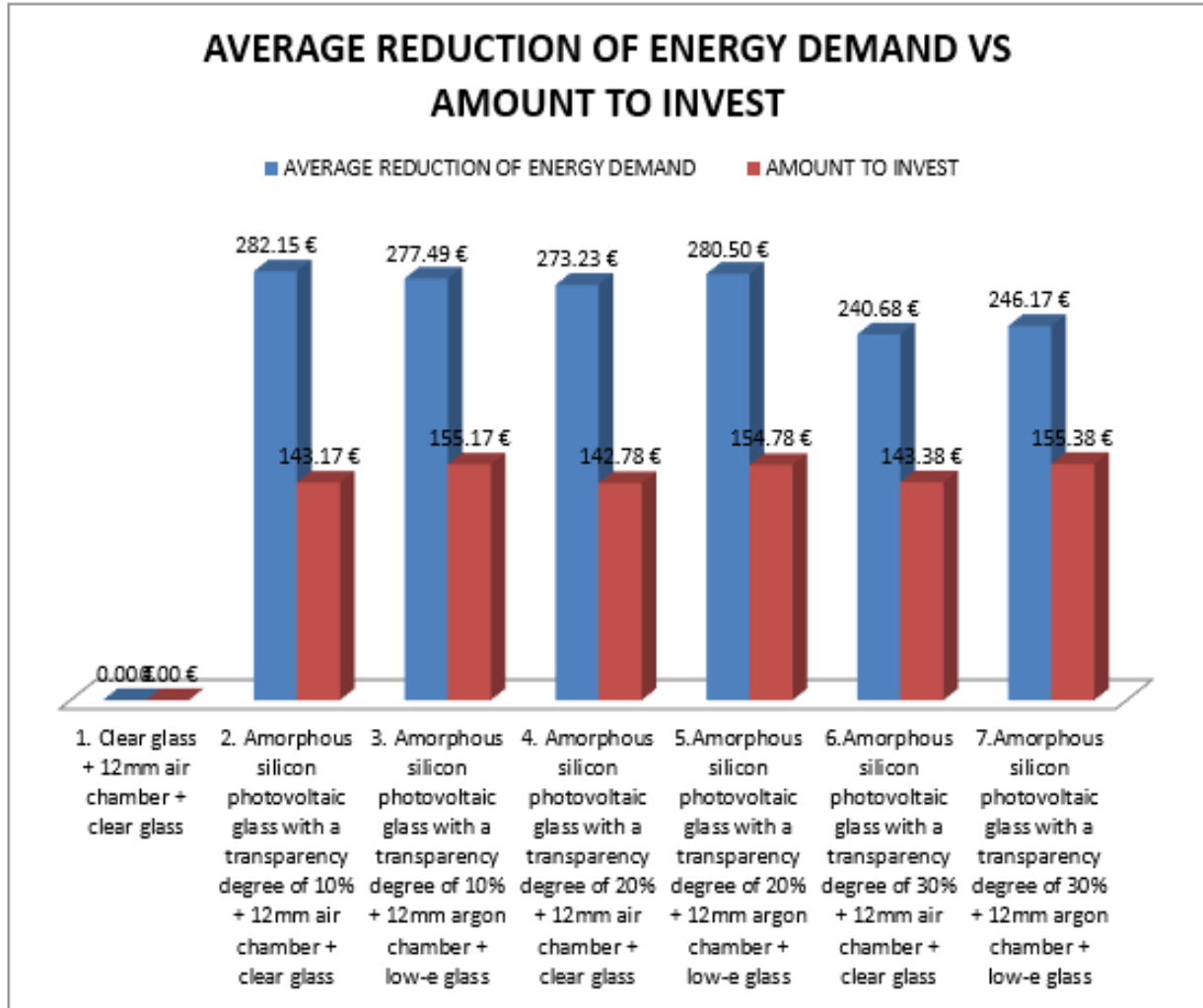

Figure 35; Average Reduction in Energy Demand vs. Amount Invested.

Table 9; Return on Investment.

RETURN ON INVESTMENT					
GLASS CONFIGURATION	AVERAGE REDUCTION OF ENERGY DEMAND	AMOUNT TO INVEST	ROI	IRR	TIMES THE INVESTMENT
	Average reduction of energy demand per square meter of glass from energy generation and the HVAC savings in 30 years	Investment needed to add Photovoltaic properties to each SQM of Glass and the Cost for the Balance of the system	Return on investment in 30 years (profit investment system)	Internal rate of return: average annual return during the first 30 years of the investment	Number of times that the amount invested is received during the investment period of 30 years (Average Reduction of Energy Demand/Investment)
	(BUR/SQM)	(EUR/SQM)	%	%	times
1. Clear glass + 12mm air chamber + clear glass	Without Solar Glass there is no additional reduction in energy demand, so no Return on the Investment is received				
2. Amorphous silicon photovoltaic glass with a transparency degree of 10% + 12mm air chamber + clear glass	282.15 €	143.17 €	97%	4%	2
3. Amorphous silicon photovoltaic glass with a transparency degree of 10% + 12mm argon chamber + low-e glass	277.49 €	155.17 €	79%	3%	2
4. Amorphous silicon photovoltaic glass with a transparency degree of 20% + 12mm air chamber + clear glass	273.23 €	142.78 €	91%	3%	2
5. Amorphous silicon photovoltaic glass with a transparency degree of 20% + 12mm argon chamber + low-e glass	280.50 €	154.78 €	81%	3%	2
6. Amorphous silicon photovoltaic glass with a transparency degree of 30% + 12mm air chamber + clear glass	240.68 €	143.38 €	68%	2%	2
7. Amorphous silicon photovoltaic glass with a transparency degree of 30% + 12mm argon chamber + low-e glass	246.17 €	155.38 €	58%	2%	2

3.11 Other advantages of Building-integrated Photovoltaic & Green Building Design

In the past decade, the issue of environmental, social, and economic sustainability has gained much traction. Among the proposed strategies for attaining sustainability in resource use and management, Green Building design and technology have become of great interest, especially in today's real estate market. This is especially true within the business model where the leasing tenants are responsible for operating and managing the Building. Qualitative facts such as return on investments, enhanced indoor comfort, and productivity level due to the radiation with optimal natural light contribute to earning green certification such as ESTIDAMA. The return on investment is the key feature of the Building-integrated photovoltaic associated with the company's commitment to preserving the environment.

Other economic benefits of the Building-integrated photovoltaic are as the following:-

- Operating cost decrease 8%-9%
- Building value increases 7.5 %
- Return on investment improves 6.6%
- Occupancy rate rises 3.5 %
- The rent ratio increases 3%

The adoption of building integrated photovoltaic panels helps save on acquiring energy by; reducing consumption and wastage of energy and producing the energy required to run and operate the Building, thus eradicating or reducing the need to purchase energy. Some of the multifunctional characteristics that make the latter possible happen: improved thermal insulation, reduced need for artificial lighting, better air quality, and indoor humidity and temperature, which generally contribute to reducing carbon footprints from buildings and structures, a step closer towards achieving environmental sustainability.

They generated solar electricity to feed the Building's electricity consumption, reducing the reliance and use of other conventional sources. The strategy is also essential in dealing with unreliable energy supply and shortage, especially in minimizing the peak load demand for HVAC and lighting (Lu, et al., 2019).

In conjunction with the ability to save energy and generate it, you will be given peace of mind knowing that the Building's energy cost will remain minimal.

3.12 Hypothesis and Assumptions

Electricity price was obtained from the United Arab Emirates, Ministry of energy, estimated at 0.06 Eur/kWh. Since Abu Dhabi is still on the verge of its growth, the demand for grid electricity is expected to increase simultaneously. This means a high probability of the electric bills going up and creating a challenge of energy shortage. Further, the high electricity demand will increase unsustainable energy generation processes like burning natural gas and other petroleum products. This is thereby threatening our environment and has been the cause of the current global

challenge of environmental pollution and climate change. As a result, there is a need to propose a sustainable source of electricity for buildings in the ‘solar-energy rich’ Abu Dhabi city.

PROTOTYPE



Stage 1

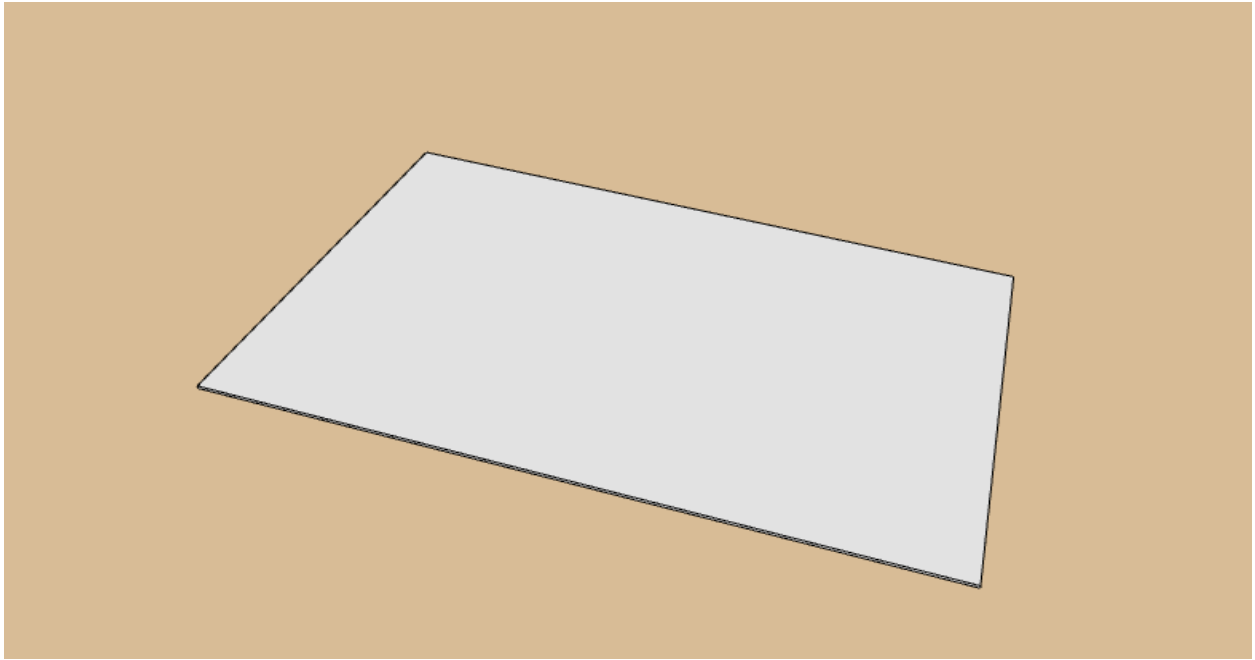

Figure 36; First step in modelling the site area was site allocation and design of the ground floor plan.

Stage 2



Figure 37; Construction of the pillars, floor slabs, and wall cladding.

Stage 3



Stage 4



Figure 38; Replacing existing wall material with ACP. This involves changing building properties in the IESVE extension on Stech-up. As well as the allocation of different settings and characteristics like thermal performance.



Figure 39; Front elevation of the complete remodelled building.



Figure 40; Side elevation of the proposed building.











4 CHAPTER 04: METHODOLOGY & STRATEGIES

4.1 Overview

We have completed energy modelling for the Y tower Adnec Building to meet the Estidama pearl two regulations. As part of our activity, we have used the project with the greenest efficient materials to suit the Estidama requirements.

The building has been constructed using; hollow, insulated, and solid blocks which measure between 100-300mm, concrete, Rockwool of 50mm thickness and 70Kg/m³ density, and finally double glazed 6mm HD reflective, 20mm ASP, and 6mm clear stunt T LowE. These materials have different properties regarding thermal efficiency, and their generation also contributes to the increase in global carbon footprint.

We modelled the building using PV facades to enable the building to harness solar energy, thus making the building more energy sufficient instead of Aluminum Composite Panels (ACP). Adopting solar PV facades, which reduce the amount of solar radiation entering the building, will also reduce the energy used for cooling and maintaining ample thermal conditions, especially during the day. This will go a long way to reducing the need for artificial cooling methods which are more energy-intensive, like the use of conventional ACs.

The effect of using Aesthetic PV facades as walling material instead of conventional Aluminum Composite Panels (ACP) and normal construction glass, which harm the environment and energy efficiency of a building, was analyzed through IES VE as a means of verifying and affirming the study.

This research can be defined as exploratory research. The study's main objective is to analyze the feasibility of using Aesthetic PV façades in place of ACP wall material to harness solar energy and make the Y Tower Adnec building sustainable efficient in energy management and generation.

Strategies: Some of the strategies employed for the study are; Literature review, Field Studies, observation, Simulation and modelling, A multi-disciplinary approach.

4.2 Field Studies/ Physical data collection

One of the most efficient and earliest methods of studying different phenomena is observation and physical data collection. It is possible to study and analyze the behaviour and characteristics of different objects. However, to capture the most relevant and applicable data, the researcher must-have skills and knowledge in the particular area of study and collect data. This will enable them to follow the given protocol and parameters to deal with externalities like missing study subjects and outliers.

After the data collection process, it is recommended that one does a follow up data collection exercise within a week or two of the official data collections to affirm critical issues and information as well as to facilitate the collection of missing data in cases where maybe the owner of the household being studied was not available during the data collection process.

In studying the energy efficiency of a building, it was essential to understand the energy consumption rates of the building in question. For this purpose, we had to visit the study area to interview its management and the Department of Energy Abu Dhabi city (DEA). This was necessary to understand the building's current energy situation and data crucial in modelling and proposing alternative green and sustainable building materials.

Jakica et al. (2019) have discussed some of the applications of BIPV systems in attaining energy-efficient properties in their document 'BIPV Design and Performance Modelling; Tools and Methods'

Saupan, 2008, in the journal titled, 'BIM + Sustainability: Case Study on IES VE Building Performance Simulation,' recommended and used IES VE to manipulate weather, temperature, and load reports collected from conducting field surveys.

In a study to assess green buildings and sustainable construction methods in the UAE, Salama & Hana (2010, pp. 1397-1405) conducted a field visit to study the awareness of different practitioners and business people in the UAE. In a study on the design and modelling of an energy-efficient HRV, Guida (2019, pp. 3713-3715). They performed several measurements to analyze features like heat loss.

From the field study, we established the following materials used to construct the Y tower Adnec Building;

4.3 Properties and characteristics of existing building material on Y-towe Adnec building

Properties of Hollow Block (100mm):

Thermal transmittance - (U) Value calculation

1. Thermal transmittance (U) value if a wall constructed using "100 mm Thick, Normal Weight Concrete Hollow Masonry Blocks" is as follows:
 - a) Wall configuration

Table 10; Calculations of the thermal transmittance (U) value of Hollow-Block wall material (100 mm Thick)

Layer	Thickness (mm)	Thermal conductivity [W/m.K]	Thermal Resistance [m ² .K/W]
External surface	--	--	0.04
Plaster	15	0.72	0.0208

Block	100	0.858	0.11655
Plaster	15	0.72	0.0208
Internal surface	--	--	0.12
TOTAL	130	--	0.31815

- See Report on Thermal Transmission Properties issued by DCL; Ref: TT-376-2017 dated 12-01-2017

b) Thermal transmittance (U-value)

Table 11; Thermal transmittance (U-value) of the 100mm thick Hollow Blocks

Description	U-value [W/(m ² .K)]
Wall Thermal Transmittance (U= 1/RT)	3.14

Properties of Hollow Block (150mm):

Thermal transmittance - (U) Value calculation

1. Thermal transmittance (u) value if a wall constructed using "150 mm Thick, Normal Weight Concrete Hollow Masonry Blocks" is as follows:

a) Wall configuration

Table 12; Calculations of the thermal transmittance (U) value of Hollow-Block wall material (150 mm Thick)

Layer	Thickness (mm)	Thermal conductivity [W/m.K]	Thermal Resistance [m ² .K/W]
External surface	--	--	0.04
Plaster	15	0.72	0.0208
Block	150	1.134	0.13228
Plaster	15	0.72	0.0208
Internal surface	--	--	0.12
TOTAL	180	--	0.33388

- See Report on Thermal Transmission Properties issued by DCL; Ref: TT-377-2017 dated 12-01-2017
- b) Thermal transmittance (U-value)

Table 13; Thermal transmittance (U-value) of the 150mm thick Hollow Blocks

Description	U-value [W/(m ² .K)]
Wall Thermal Transmittance (U= 1/RT)	3.00

Properties of Hollow Block (200mm):

Thermal transmittance - (U) Value calculation

1. Thermal transmittance (U) value if a wall constructed using "200 mm Thick, Normal Weight Concrete Hollow Masonry Blocks" is as follows:
 - a) Wall configuration

Table 14; Calculations of the thermal transmittance (U) value of Hollow-Block wall material (200 mm Thick)

Layer	Thickness (mm)	Thermal conductivity [W/m.K]	Thermal Resistance [m ² .K/W]
External surface	--	--	0.04
Plaster	15	0.72	0.0208
Block	200	1.272	0.15723
Plaster	15	0.72	0.0208
Internal surface	--	--	0.12
TOTAL	230	--	0.35883

- See Report on Thermal Transmission Properties issued by DCL; Ref: TT-378-2017 dated 12-01-2017
- b) Thermal transmittance (U-value)

Table 15; Thermal transmittance (U-value) of the 200mm thick Hollow Blocks

Description	U-value [W/(m ² .K)]
Wall Thermal Transmittance (U= 1/RT)	2.79

Properties of Insulated Block (200mm):

Thermal transmittance (U) Value calculation

Reference is made to your application dated 30/08/2016 regarding the subject above. Please note the following:

1. Thermal transmittance (U) value if a wall constructed using "200 mm Thick, Normal Weight Concrete – Polystyrene Sandwich Masonry Hollow Blocks with 60mm thick Expanded polystyrene insert" is as follows:
 - a) Wall configuration

Table 16; Calculations of the thermal transmittance (U) value of Insulated-Block wall material (200 mm Thick)

Layer	Thickness (mm)	Thermal conductivity [W/m.K]	Thermal Resistance [m ² .K/W]
External surface	--	--	0.04
Plaster	15	0.72	0.0208
Block	200	0.110	1.81818
Plaster	15	0.72	0.0208
Internal surface	--	--	0.12
TOTAL	230	--	2.01978

- See Report on Thermal Transmission Properties issued by DCL; Ref: TT-347-2016 dated 21/09/2016

- b) Thermal transmittance (U-value)

Table 17; Thermal transmittance (U-value) of the 200mm thick Insulated Blocks

Description	U-value [W/(m ² .K)]
Wall Thermal Transmittance (U= 1/RT)	0.50

Properties of Insulated Block (250mm):

Thermal transmittance - (U) Value calculation

1. Thermal transmittance (u) value if a wall constructed using "250 mm Thick, Normal Weight Concrete-Polystyrene Sandwich Masonry Hollow Blocks with 60mm thick Expanded polystyrene insert" is as follows:
 - a) Wall configuration

Table 18; Calculations of the thermal transmittance (U) value of Insulated-Block wall material (250 mm Thick)

Layer	Thickness (mm)	Thermal conductivity [W/m.K]	Thermal Resistance [m ² .K/W]
External surface	--	--	0.04
Plaster	15	0.72	0.0208
Block	250	0.134	1.86567
Plaster	15	0.72	0.0208
Internal surface	--	--	0.12
TOTAL	280	--	2.06727

- See Report on Thermal Transmission Properties issued by DCL; Ref: TT-381-2017 dated 12-01-2017

- b) Thermal transmittance (U-value)

Table 19; Thermal transmittance (U-value) of the 250mm thick Insulated Blocks

Description	U-value [W/(m ² .K)]
Wall Thermal Transmittance (U= 1/RT)	0.48

PRODUCT: 250mm thick Concrete-Polystyrene Sandwich Hollow Masonry block
 Normal Weight Concrete-Polystyrene Sandwich Masonry
 Hollow Blocks

PRODUCT DESCRIPTION : (400*250*200)mm with 60 mm thick Expanded polystyrene insert

PRODUCT WEIGHT (K.G.): 30

PRODUCT THICKNESS (M): 0.25
 (PERPENDICULAR TO
 HEAT FLOW DIRECTION)

PRODUCT CONFIGURATION :

Table 20; Product configuration table

Product's COMPONENTS	DENSITY [kg/m ³]	THERMAL CONDUCTIVITY [W/m. K]	CONDITION OF TEST % R.H.	°C	TEST REPORT / REFERENCE
Concrete	2300	1.84	--	--	D.M. approved materials list
Polystyrene	32	0.0367	60±5	35±2	DCL report no.2016011109 insert manufactured by

CALCULATION RESULTS	UPPER LIMIT	LOWER LIMIT	AVERAGE
THERMAL RESISTANCE [m ² .K/W]	1.945	1.773	1.859
EQUIVALENT THERMAL CONDUCTIVITY [W/m. K]			0.134

Properties of Insulated Block (300mm):

Thermal transmittance - (U) Value calculation

1. Thermal transmittance (U) value if a wall constructed using "300 mm Thick, Normal Weight Concrete-Polystyrene Sandwich Masonry Hollow Blocks with 160mm thick Expanded polystyrene insert" is as follows:
 - a) Wall configuration

Table 21; Calculations of the thermal transmittance (U) value of Insulated-Block wall material (300 mm Thick)

Layer	Thickness (mm)	Thermal conductivity [W/m. K]	Thermal Resistance [m ² .K/W]
External surface	--	--	0.04
Plaster	15	0.72	0.0208
Block	300	0.067	4.47761
Plaster	15	0.72	0.0208
Internal surface	--	--	0.12

TOTAL 330 -- 4.67921

- See Report on Thermal Transmission Properties issued by DCL;
Ref: TT-382-2017 dated 12-01-2017

b) Thermal transmittance (U-value)

Table 22; Thermal transmittance (U-value) of the 300mm thick Insulated Blocks

Description	U-value [W/ (m ² .K)]
Wall Thermal Transmittance (U= 1/RT)	0.21

Properties of Solid Block (100mm):

Thermal transmittance - (U) Value calculation

1. Thermal transmittance (u) value if a wall constructed using "100 mm Thick, Normal Weight Concrete Solid Masonry Blocks" is as follows:

a) Wall configuration

Table 23; Calculations of the thermal transmittance (U) value of Solid-Block wall material (100 mm Thick)

Layer	Thickness (mm)	Thermal conductivity [W/m.K]	Thermal Resistance [m ² .K/W]
External surface	--	--	0.04
Plaster	15	0.72	0.0208
Block	100	1.840	0.05435
Plaster	15	0.72	0.0208
Internal surface	--	--	0.12
TOTAL	130	--	0.25595

- See Report on Thermal Transmission Properties issued by DCL;
Ref: TT-371-2017 dated 12-01-2017

b) Thermal transmittance (U-value)

Table 24; Thermal transmittance (U-value) of the 100mm thick Solid Blocks

Description	U-value [W/(m ² .K)]
Wall Thermal Transmittance (U= 1/RT)	3.91

Properties of Solid Block (150mm):

Thermal transmittance - (U) Value calculation

1. Thermal transmittance (u) value if a wall constructed using "150 mm Thick, Normal Weight Concrete Solid Masonry Blocks" is as follows:
 - a) Wall configuration

Table 25; Calculations of the thermal transmittance (U) value of Solid Block wall material (150 mm Thick)

Layer	Thickness (mm)	Thermal conductivity [W/m. K]	Thermal Resistance [m ² .K/W]
External surface	--	--	0.04
Plaster	15	0.72	0.0208
Block	150	1.840	0.08152
Plaster	15	0.72	0.0208
Internal surface	--	--	0.12
TOTAL	180	--	0.28312

- See Report on Thermal Transmission Properties issued by DCL;
Ref: TT-372-2017 dated 12-01-2017

- b) Thermal transmittance (U-value)

Table 26; Thermal transmittance (U-value) of the 150mm thick Solid Blocks

Description	U-value [W/ (m ² .K)]
Wall Thermal Transmittance (U= 1/RT)	3.53

Properties of Solid Block (200mm):

Thermal transmittance - (U) Value calculation

1. Thermal transmittance (u) value if a wall constructed using "200 mm Thick, Normal Weight Concrete Solid Masonry Blocks" is as follows:

- a) Wall configuration

Table 27; Calculations of the thermal transmittance (U) value of Solid-Block wall material (200 mm Thick)

Layer	Thickness (mm)	Thermal conductivity [W/m.K]	Thermal Resistance [m ² .K/W]
External surface	--	--	0.04
Plaster	15	0.72	0.0208
Block	200	1.840	0.1087
Plaster	15	0.72	0.0208
Internal surface	--	--	0.12
TOTAL	230	--	0.3103

- See Report on Thermal Transmission Properties issued by DCL;
Ref: TT-373-2017 dated 12-01-2017

- b) Thermal transmittance (U-value)

Description	U-value [W/(m ² .K)]
Wall Thermal Transmittance (U= 1/RT)	3.22

INSULATED GLASS PROPERTIES:

Table 28; Insulated glass properties performance calculations (Source; Guardian Glass)

Table 29; Insulated glass properties sum PRODUCT CONFIGURATION marry table (Source; NFRC 2010)

Summary Data					
Calculation Standard: NFRC 2010					
Visible Light		Solar Energy		Other Data	
Transmittance % (τ_v)	15	Solar Heat Gain Coefficient (SHGC)	0.17	Sound Transmission Class (STC)	34
Reflectance-In % (ρ_v)	21	Shading Coefficient (sc)	0.19	Weighted Sound Reduction Index (R_w)	34
Reflectance-Out % (ρ_v)	13	Relative Heat Gain (RHG)	128	Outdoor Indoor Transmission Class (OITC)	29
Color Rendering Index % (R_a)	93.9	Transmittance % (τ_g)	9	Wind Speed	5.50
Light to Solar Gain (LSG)	0.90	Reflectance-In % (ρ_g)	37	Draft Speed	0
Thermal Properties		Reflectance-Out % (ρ_g)	15		
U-Value Winter Night ($W/m^2 \cdot K$)	1.74	Absorptance % (α_g)	75		
U-Value Summer Day ($W/m^2 \cdot K$)	1.16	Ultraviolet % (τ_{UV})	5		
R-value ($m^2 \cdot K/W$)	0.58	Damage-weighted Transmittance % (Tdw)	10		
		Thermal Stress Guidance (Center of Glass)	Stop		

ROCKWOOL TECHNICAL PROPERTIES:

**Fujairah Rockwool Slabs
with Aluminum Foil Facing on one side
S@XX**

Thickness: 50mm
Density: 70kg/m³

Fujairah Rockwool Slabs are produced from a long noncombustible resin material known for its excellent load-bearing performance. The material has been made in conformance with the ASTM C-612 and BS-3958-5, and they are designed mainly to facilitate acoustic and thermal insulation. The installation of these materials is easy and does not require much skill as they are easy to cut and install, even on curved surfaces.

Service Temperature

Plain Rockwool Insulation has a service temperature of 780°C when tested following DIN 52271 for 80mm thickness and 100kg/m³ density. However, there is a possible deviation for lower densities and with facings.

the user is advised that the maximum use temperature of facings and adhesives may be lower than the maximum use temperature of the insulation. The user shall ensure that sufficient thickness shall be installed so none of these accessory items (facings and adhesives) and exposed to temperatures above their maximum use temperature.

Applications

Designed for a wide range of applications at both high and low service temperatures. It can be used on flat and slightly curved surfaces for thermal and acoustic insulation of ducting, ovens, vessels, and other industrial equipment. Ideal for insulation of flat surfaces of furnaces, boilers, and tanks. It is also suited for fire protection of steel structures, insulation of bulkheads, and ship decks.

Standard Delivery

Available in a standard width of 600mm and length of 1200mm.
Other sizes are available at the client's request.

Moisture

The materials are water repellent, non-hygroscopic, non-capillary, and do not absorb moisture from the air. Moisture does not affect the stability of the slabs. Water absorption test certificates conducted under BS 2972: Section 12 and ASTM C-209 are available upon request.

Thermal Conductivity

Fujairah Rockwool products show remarkably low thermal conductivity values with typical figures under BS 874, equivalent ASTM C 177/C 518. We have test reports at 35°C mean temperature for 40kg/m³, 70kg/m³, and 110kg/m³ densities.

Table 30; Rockwool material thermal conductivity.

Mean Temp °C	k-Value W/mK 70 kg/m³
24	0.035
35	0.037
50	0.039
100	0.046
150	0.057
200	0.069
250	0.084
300	0.102
350	0.121
400	0.140

The table shows the test results for their raw density following the test report. These results are not binding because they were converted

Acoustic Properties

Typical Sound absorption figures are shown below, following BS 3638 & ISO 354 and equivalent ASTM C 423. We have test certificates for 70kg/m³ and 100 kg/m³ densities.

The tables show the test results for their raw density per the test report.

These results are not binding because they were converted

Table 31; Rockwool acoustic properties.

Hz	70 kg/m³
125	0.22
250	0.62
500	0.91
1000	1.00
2000	1.00
4000	0.98

Table 32; Rockwool nominal material density and fire protection capabilities.

<p>Fujairah Rockwool (SBXX and SBBX)</p>	<p>Mineral Fiber Slab/Board with Black Aluminium Foil Facing Nominal Thickness, 25-200mm</p> <p>Fire Properties – Class A (Flame Spread ≤ 25 and Smoke Developed Index ≤ 450) (see note 3)</p> <ol style="list-style-type: none"> 1. Nominal Density, 30 – 40kg/m³; K-Value: 0.046 W/(m*K) MW-EN13162-T3—CS(10)0.5-MU3 2. Nominal Density, 41 – 60kg/m³; K-Value: 0.042 W/(m*K) MW-EN13162-T3—CS(10)0.5-MU3 3. Nominal Density, 61 – 120kg/m³; K-Value: 0.038 W/(m*K) MW-EN13162-T3—CS(10)0.5-MU3 4. Nominal Density, 121 – 200kg/m³; K-Value: 0.039 W/(m*K) MW-EN13162-T3—CS(10)0.5-MU3
--	--

4.3.1 Advantages and Disadvantages of Field Studies

The method is quite cheap and simple, especially where the period of study is short and the task or the phenomena being studied doesn't need long periods of study. Although it may require some skill level, simplifying the study needs and data collection methods makes the process easier even for unskilled personnel.

Through conduction field surveys and studies, it is possible to study various unrecorded phenomena and data. In some cases, it is the only applicable method of acquiring and recording primary data and information when dealing with objects or animals.

It is impossible to see some things on the shortcomings of the observation and field study of energy efficiency in buildings. Factors like the solar radiation material and the materials' heat gain and loss properties are not observable. Energy usage can also not be observed unless with the help of devices monitoring and measuring devices like meters.

4.4 Literature Review

A literature review provides the theoretical foundation by substantiating the research problem and justifying research by validating or mystifying previous studies and strengthening the valid ones Report on Thermal Transmission Properties.

Abu Dhabi is located in an arid desert kind of climate. Manandhar et al. (2020) have indicated that Abu Dhabi City experiences a challenge of Urban Heat Islands (UHI) due to the congestion in the built environment, use of poor energy performance materials, and daily activities like transport and industrial activities.

Having identified the materials used in the construction of the Y tower Adnec building, concrete, Rockwool, and double glazed, it was crucial to analyze various sources for their thermal performance analysis. Former researches and analysis by material developers and standardization bodies like the ISO 6946 have come up with calculation methods of the thermal performance of conventional materials and new materials invented by the day (NSAI, 2017). The same bodies have also developed performance standards for ensuring that all buildings are built in an environmentally friendly, resilient, and sustainable manner. Some of the construction standards relevant in the UAE are the Estidama and Dubai-Green Building Rating Systems and standards.

Al-Ayish (2017) recommends using renewable construction materials rather than conventional building materials like concrete blocks and aluminium composite panels (ACP). These materials also have high solar radiation properties, thus leading to massive heat gains during the day and heat loss during the night, which necessitates the use of HVAC systems which are very energy-intensive. Adopting alternative material that facilitates the retention of heat energy and ample air circulation reduces the building's energy consumption quite significantly.

Jakica et al. (2019), in their document on 'BIPV Design and Performance Modelling,' have highlighted some of the advantages of using PV systems, especially in sustainable building design. This is through the adoption of PV façades instead of aluminium composite panels (ACP).

4.4.1 Advantages and Disadvantages of Literature Review

Analyzing data from previous research and work enables one to familiarize themselves with the phenomena being studied and get tested information that forms the research base. The method is also very cost and time-efficient since it does not call for inconveniences like travelling and source data from people who might not be cooperative.

In our case, relying purely on the findings of the Literature Review would not be sufficient for the research since we also need to acquire actual data on the building being studied by Estidama calculation and simulation to model and analyze the performance of the building in energy efficiency.

4.5 Simulation and Modelling

Modernization and technology have not left the building and construction industry behind. Innovators, scientists, and professionals in the built environment have developed Building Integrated Modelling (BIM) systems to assist in the management of; design, construction, monitoring, and evaluation, among other processes (Diaz 2016). BIM systems also come with

the value-added advantage of allowing various entities and professionals to collaborate on projects by allowing involved parties to access project data shared on the cloud (Diaz 2016). Anyone with access to the data can make changes and highlight areas of key concern from their comfort areas, thus making the process even more efficient. These systems come with the ability to view, design, and analyse data in the conventional 2D options and allow 3D and 4D modelling and viewing.

Jakica et al. (2019), in their report aimed at investigating BIPV Design and Performance Modelling Tools and Methods, have discussed the importance of BIM systems in the analysis of the following aspects of BIPV systems;

Evaluation of technical and financial feasibility of the proposed project by analyzing possible risks and negative impacts of a project. Using proven technologies and materials, it is possible to mitigate and overcome some of these risks and impacts and perform a cost-benefit analysis, thus developing an economical, energy-efficient, and sustainable project.

Levelized cost of electricity calculation is a tool that enables the calculation and measurement of the energy cost of a given building which is then compared against alternative energy production methods and strategies. In brief, the average cost of building and operating a property generates its energy weighed against the total value of the electricity generated over the building's operation.

Jin et al. (2019) suggest that simulation is a crucial part of the planning and installation of BIPV systems. This enables the development of more adaptable systems through technical and economic feasibility analysis.

Solar irradiation calculation is necessary, especially when it comes to setting up BIPV systems or in the installation of HVAC efficient systems and plants. The use of suitable material reduces the amount of energy used in the cooling and heating of the building and the management of air quality and circulation in the property (International Energy Agency 2019).

Other forms of analysis include; shading loss analysis, optimization of cell arrays layout, 3D design, and the optimization of hybrid renewable technology (Amoruso et al., 2019).

4.5.1 Advantages and Disadvantages of Simulation and Modelling

Building Information Modelling systems are essential when it comes to modelling and simulation, and management of construction projects. BIM systems are essential in modelling new buildings and enable the management of functional properties and their renovation and retrofitting programs (Li et al., 2014). Diaz (2016, p. 5) highlights that modelling and simulation are important, especially in delivering tested and assured high energy and resource-efficient building and projects, therefore, reducing carbon emissions. BIM systems are flexible enough to be used in various projects and environments by setting the parameters and manipulating set

parameters to get the desired results. Li et al. (2014, p. 1) have indicated that “BIM systems made it possible to model even the most complex spaces and designs,” this is not only in 2D but also in 3D and 4D. This enables clash detection in projects way before they have been set up, thus making it possible to fix errors quickly. The ability to manipulate data and information in shared BIM formats enables the study of different data and results in different disciplines (Li et al., 2014). Saupan et al. (2008) have discussed the role of BIM modelling and simulation platforms in speeding up a project’s timeline.

However, using most of this software requires skill and knowledge. Despite the numerous capabilities of different BIM software, they are still incapable of conducting all the necessary studies by themselves, thereby requiring one to have skill in a multi-discipline of software for a sufficient and efficient study.

4.6 Adopting a Multidisciplinary Approach

According to Attoye et al. (2018, p. 7), there is a need to adopt a multi-disciplinary approach in developing and installing BIPV systems. This is because environmental, social, and economic sustainability and conservation are cut across all disciplines. It is also crucial to note that such projects are usually capital intensive, especially where whole systems are being installed, thus necessitating the collaboration of the private sector, government entities, and international organizations like the UNEP. The interaction of various disciplines will help sustainable and resilient solutions by ensuring that all aspects of human life are given key consideration.

We chose to apply a multidisciplinary approach that involves employing different principles and integrating software functions to generate the desired results.

4.6.1 Advantages and disadvantages of the multidisciplinary approach

Improved communication happens to be among the basic principles of collaboration. Having people from different disciplines necessitates clear, precise, and easily understandable language and formats, which is important in ensuring that stakeholders and the public can understand the project’s construction and operation process and activities.

Foster collaboration skills by enabling different professionals to develop a common language to attain positive desired results. This is essential even for future endeavours since the teams will be more skilled and able to communicate and work with each other, thus achieving even better results.

Different disciplines complement each other since they all deal with different aspects and phenomena of life, e.g., medicine, environmental studies, energy management industries. These groups hold different information as well as solutions to challenges, which is important in the development of social, environmental, and economically sustainable projects while at the same time safeguarding the health and safety of the users (Tang & Hsiao 2013).

Having different professionals work together has also been proven to improve the sense of achievement and inclusion by various entities by contributing to the setting up of the project. This also creates a sense of pride and ownership in a project, a factor that contributes towards a project's success.

On the other hand, integrating different disciplines and professions in any project brings about time constraints in the process of decision making since the members from different disciplines need to come to a consensus before surging forward. This makes the decision-making process longer and more costly. Bringing people from diverse education and life backgrounds to work together and collaborate on a project is a very perilous task due to differences in understanding various concepts and strategies (Tang & Hsiao 2013).

4.7 Integrated Environmental Studies- Virtual Environment (IES-VE)

IES-VE is one of the many BIM software's that enables a researcher to analyze the performance of a building in terms of energy use and efficiency and the reduction of carbon emissions. The software enables the researcher to analyze the efficiency and conditions of lighting systems, solar energy, energy efficiency. Using the software, one can simulate the study environment. The first step towards analyzing the energy efficiency of a building using IES-VE is modelling the study area using the Model IT module. Here one can draw and assign various construction materials and designs in creating the building to be analyzed. This can be done from scratch or through importing 3D and 2D plans from various design software like ArchiCAD and Google Sketch-up. The platforms offer various modelling materials necessary for analysing Wood, concrete, steel, masonry, and hybrid materials like PV systems.

The software uses information acquired from various building standards and systems, e.g., the ISO standards, Asharae building standards, and Estidama Pearl rating systems.

Using the Sun Cast module, it is possible to analyze for shading and visualization. The module can display the effect of the building on the adjacent environment's shading and vice versa. These aspects are displayed in 3D format, allowing one to see and trace the sun's path and its angle and position all year round. The thermal properties of the building are analyzed using the Apache thermal analysis. Through various aspects of the Apache thermal analysis module, calculations and descriptive can be given even in graphs and other visual presentation formats.

IES VE also enables one to study and compare the energy load of a building's systems, e.g., lighting, ventilation, and air conditioning systems. One can also study and compare the impacts and effects of using more energy-efficient methods and systems.

ApacheHVAC enables the assembly, modelling, and analysis of buildings' heating, ventilation, air conditioning plants, and control systems. ASHRAELoads is used to calculate HVAC loads and sizing by basing the analysis on the ASHRAE Heat balance method. The module can also be linked with various other modules in the program like SUN Cast and ApacheHVAC.

CIBSELoads is another tool in the program that facilitated the calculation and analysis of heat

loss gained by comparing and basing them on the CIBSE Guide. Using ApacheSim, one can simulate and assess various thermal performance aspects and share data within different environmental analysis programs. Other tools and modules include; VE-Navigator for ASHRAE 90.1 used for LEED Energy Modeling and Energy Cost Budget analysis and PiscesPro used for the design and modelling of piping systems.

The analysed data aspects are compared against the area's real-time weather data to make it more accurate and relevant to the area of study. The location and site data interface allows users to select different weather presets according to their study area. Our project adopted the Abu Dhabi International Airport as the nearest reference point for the study area's weather and climate settings.

We were able to use the software to model the existing building as well as model the building inclusive of proposed renovations and changes using the proposed energy-efficient material to study and compare the difference and impact in energy loads and requirements before and after installing the Aesthetic PV facades as an alternative to Aluminum Composite Panels (ACP) in the existing combination of external wall construction material. Understanding the sun's path was also a crucial part invalidating our study since its main aim is to achieve energy efficiency and sufficiency. This is through using more natural lighting and heating through ideal materials, thus reducing the negative carbon impacts of the building and minimizing the cost of acquiring energy.

4.7.1 Advantages and Disadvantages of IES-VE

Saupan et al. (2008) have discussed some of the following functions and advantages of using IES VE. They are the ability to;

Explore the energy efficiency of standard building designs. This is through enabling the modelling and analysis of the performance of various building materials and technologies. The Software enables the user to understand and analyze factors like wind orientation, building loads, and the impact of different designs, construction methods, and building materials.

The ability to incorporate sustainable principles in selecting suitable material, water use, and energy efficiency design. This is through investigating and designing new building materials and analysing their impact on green and sustainable building.

Like all BIM systems and software, IES-VE is not self-sufficient, thus requiring integration with other software and system to get the expected results. Using the software also requires some level of skill and prowess.

4.8 IES VE Integration with Sketch-Up

Like other BIM design tools like Revit, Sketch-up has been integrated with IES VE systems. Through the IES VE Sketch-Up plugin, the researcher or user can choose desired material and

construction information ranging from the property's location, room types and use, building type, HVAC systems, and construction types. After entering these details, the user can import the model and related data directly into IES VE software for analysis, cutting the need to use the Model IT component to re-build the building.

Some of the functions and features include; translating SketchUp models directly into IES VE usable files, the ability to allocate various material different properties as well as the buildings location settings and parameters, thus enabling their study, displaying the effects of different design options, which enables easy management of the project through BIM systems which allow various analysis like energy efficiency, and enabling the user to calculate and evaluate the performance of building they are studying against set standards and compliance measures like the Estidama Pearl Building Standards.

4.9 Sun Path Analysis

The Sun's path, direction, and angle are crucial, especially when harnessing solar energy (Ruiz & Bandera 2014). There is a need to understand the sun's path to identify possible challenges like obstruction and shading effects due to the orientation of the building. To analyze the sun's path to the site area, the Y Tower Adnec building, we used the Curic Sun Path Analysis Sketchup extension and Andrewmarsh.com 3D sun analysis tools.

From the Andrewmarsh.com 3D analysis tool, it is clear that the Abu Dhabi, Muskat region receives sunlight and solar radiation all year long. The sun is visible for an average of 13hrs per day, with sunrise and sunset during the longer days of the year being from 0500hrs-1900hrs as presented in Figure 1. Further, the sun's path was analyzed to the site using the same platform. The sun's path hardly closes to the North, thus a presumed shading effect apart from during the

equinox, where the sun is usually overhead in the area.

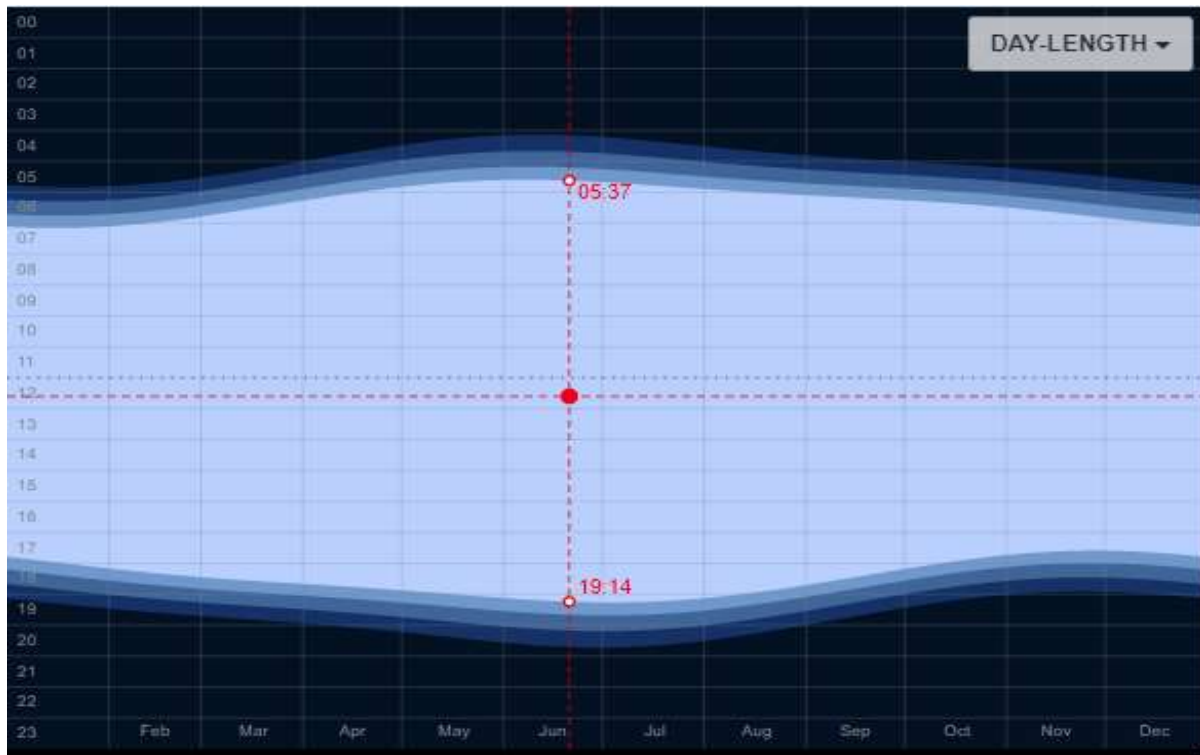

Figure 41; Abu Dhabi's Day length chart (Source; Adrewmarsh.com 3D Online Sun Path Analysis Tool)

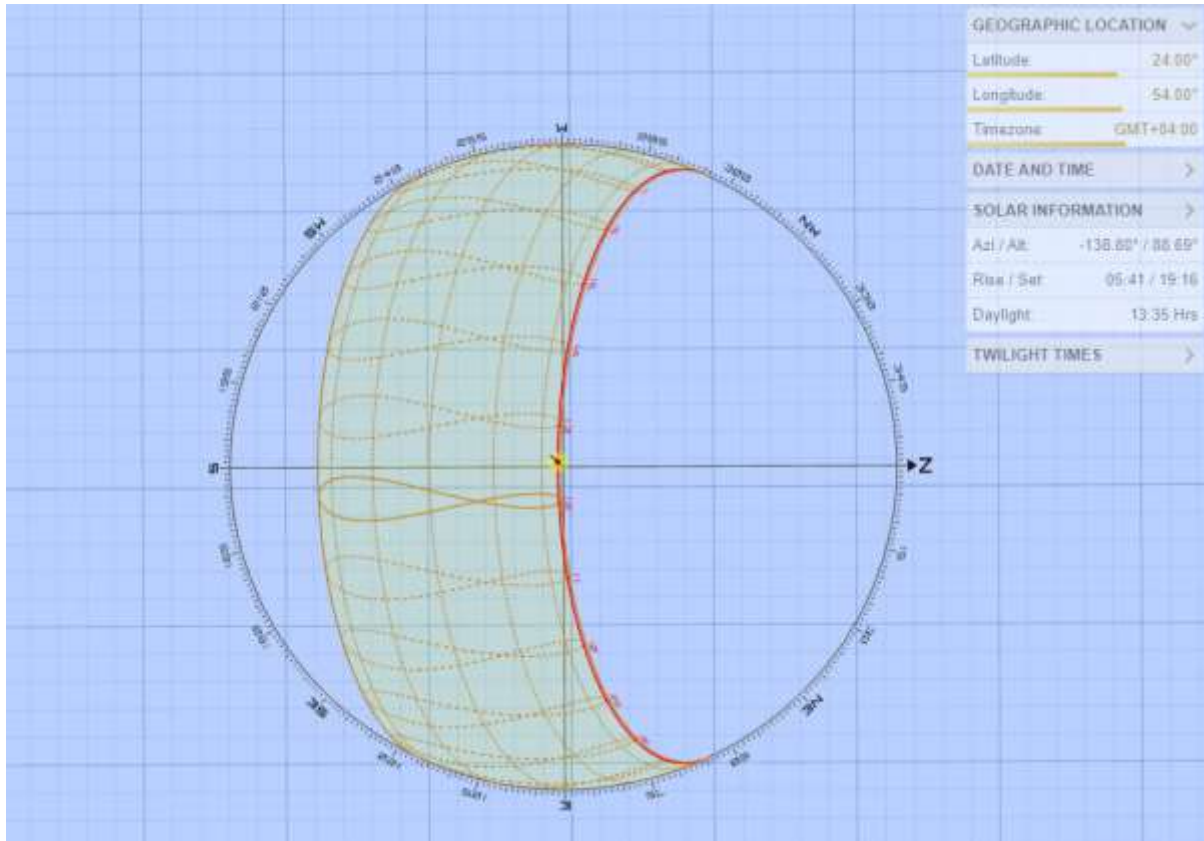

Figure 42; Abu Dhabi's Sun Path Analysis (Source; Adrewmarsh.com 3D Online Sun Path Analysis Tool)

A sun path analysis was conducted to understand the sun's path to the study area, the Y Tower Adnec building. This was analyzed using the Curic Sun Path Analysis extension on Sketchup. We analyzed the Sun's path using the building's 3D model, created on Sketchup. The buildings are positioned with the front façade facing southeast. The building's orientation and position is a plus since it puts the building at the centre of the sun's path all year round. This eliminates the shading effect resulting from the area's sun path where the Northside is usually shaded or blocked from the sun all year round apart from during the equinox when the sun is overhead. Due to the buildings positioning to the sun's path, the building's front façade, which faces southeast, and back façade to the northeast, are usually exposed to the sun during the early morning hours. As the sun's azimuth and angle change as sunset approaches, the sun shines in the northwest and southwest direction, thus creating a shadow effect on the latter façades. Aesthetic PV panels allow sunlight into the building, a feature that will ensure that the panels are on the opposite side of the sun, thus allowing all the panels to perform and generate power efficiently throughout the day. From these results, it is clear that the project idea is to replace the existing ACP walling material with aesthetic PV facades that will enable the building to harness and produce its energy.

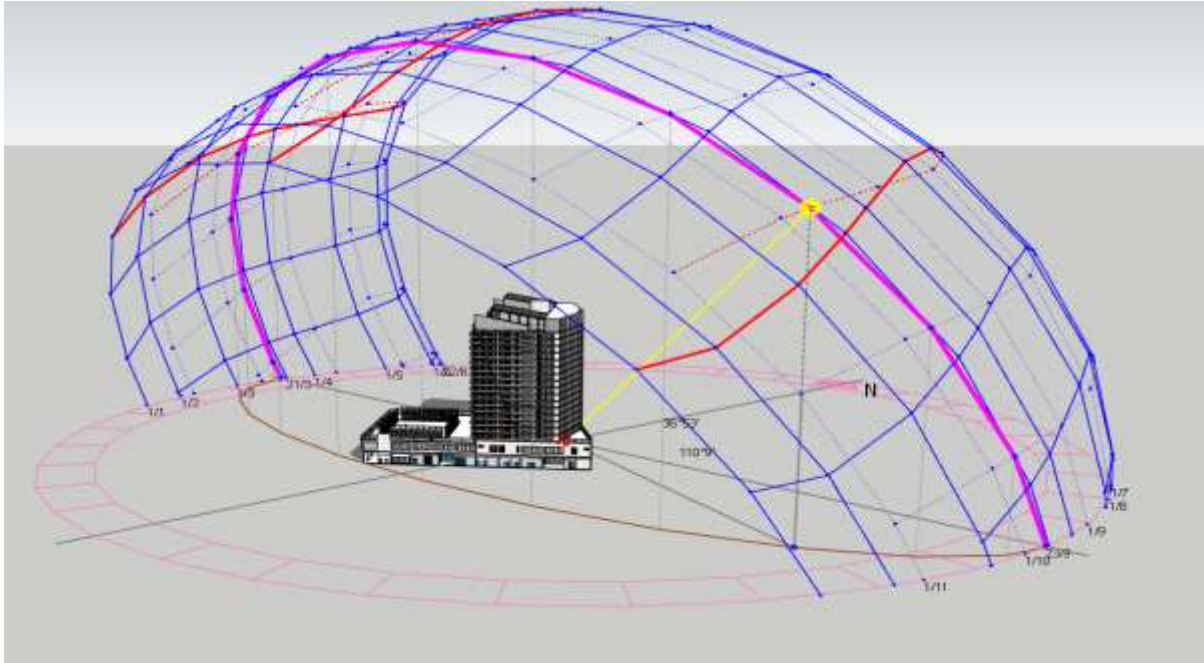

Figure 43; The Y Tower Adnec Building's Sun Path analysis (Morning hours) (Source; Curic Sun Path Analysis-SketchUp extension). Note the shaded north-west and south-west façade during the morning hours.

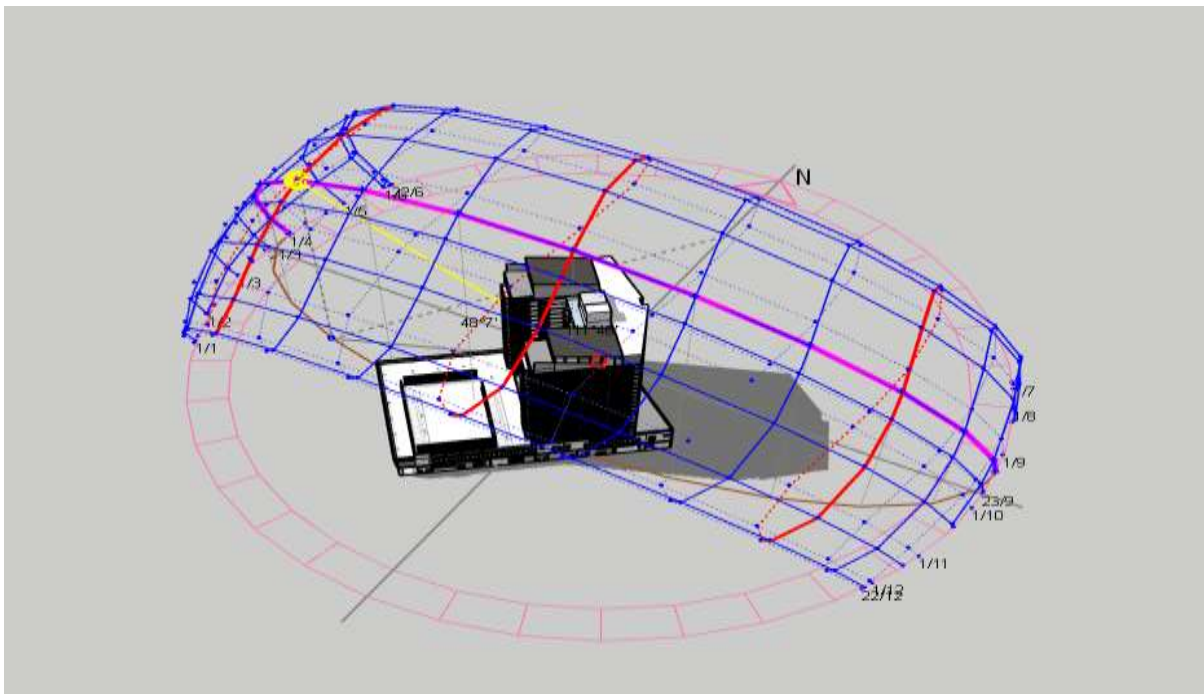

Figure 44; The Y Tower Adnec building sun path analysis. (Source; Curic Sun Path Analysis-SketchUp extension).

4.10 Calculations and Estimations

Since we aim to make the Y Tower Adnec building, Abu Dhabi, more energy-efficient by replacing the current Aluminium Composite Panels (ACP) walling material with aesthetic PV façades, it is crucial to understand the buildings current energy-saving potential. We acquired the basic raw data of the materials from consultants and calculated their energy-saving potential based on the set standards of the Estidama. The construction material cannot generate renewable energy, thus a 0.0% RE-6. From the base model calculations, the current wall, Rockwool, and ACP panels have an energy-saving potential of 24.8%.

Table 33; Estidama Renewable Energy (RE) generation calculations of Y Towers Adnec (Source; Author).

ESTIDAMA CALCULATION RE:

Baseline Building Annual Energy Consumption, kWh	5,903,649.3
Baseline Building Annual Energy Consumption, Wh/m ²	116,072.4
Proposed Building Annual Energy Consumption, kWh	4,437,092.0
Proposed Building Annual Energy Consumption, Wh/m ²	87,238.2
Annual Renewable Energy Generation, kWh	0.0
Percentage of Energy from Renewables (RE-6)	0.0%
Total Percentage Reduction (RE-1)	24.8%

Next, we calculated the building's energy-saving performance of the proposed aesthetic PV panels. The basic raw data of the aesthetic PV panels was also derived from a consultant, and calculations were done per the Estidama standards. The energy generated from the aesthetic PV panels was calculated by finding the product of the total solar panel area (A), multiplied by; the solar panel yield or efficiency (r), the average annual solar radiation on panels (H), and the performance ratio (PR).

$$E = A \times r \times H \times PR$$

Table 34; Panel Yield Calculation (Source; Author)

<u>Panel Yield Calculation:</u>	
MWP	
Min Wp/sqm	Max Wp/sqm
110	150

R= 130 Wp/sqm

Table 35; Energy generation calculation table (Source; Author)

Total Solar Panel Area = A (sqm)	3150
Solar Panel Yield or Efficiency =r	
Average Annual Solar Radiation on Panels =H	
PR = Performance Ratio	
E	1494675KWPH Per Year

Table 36; Energy generation potential and unit cost benefit per year calculations (Source; Author)

Calculations:	
E = A X MWP = 3150 sqm X 130 Wp/sqm	409500 WpH
Divided by 1000	409.5 KWpH
10 Hours Sunshine Time	4095 KWpH per Day
For 365 Days	1494675 KWpH per Year
Unit Cost Considering 25 Fils per KWH	373668.8 AED per Year

From the calculations, the solar panels will generate about 1494675 KWPH Per Year with an annual unit cost of 373668.8 AED per year, as shown in Table (). The next step is calculating the cost-benefit of the project. This is calculated by subtracting the total cost of installing the aesthetic PV panels against installing the Aluminum Composite Panels (ACP). The cost for installing the aesthetic PV panels is 1,512,000 (AED). To estimate the number of years, we divided the excess cost by the unit cost-benefit (373668.8 AED per Year). From the calculations, it will take approximately seven years for the project to make returns on the incurred installation cost.

Table 37; Cost vs returns analysis. (Source; Author).

<u>COST INCURED VS RETURN:</u>	
Energy Savings Per Year	373668.8 AED per Year
Aluminium Composite Panel COST	1512000 (AED)

Excess Cost	1,138,331.2 (AED)
No OF Years to Pay the Cost= Excess cost divided by Unit cost benefit per year	4.046364 Approx.: 4 Years

Finally, we calculated the energy efficiency of the building with the proposed aesthetic PV panels. Since the aesthetic PV’s have an energy-generating percentage of about 33.7%, the total energy efficiency potential of the building will be 50.2% generated from adding the buildings energy saving capability with the renewable power generation capabilities.

Table 38; Energy efficiency calculation with aesthetic PV panelled glass. (Source; Author)

ENERGY EFFICIENCY CALCULATION WITH AESTHETIC SOLAR PANNELD GLASS:

Baseline Building Annual Energy Consumption, kWh	5,903,649.3
Proposed Building Annual Energy Consumption, kWh	4,437,092.0
Annual Renewable Energy Generation, kWh	1,494,675.0
Percentage of Energy from Renewables (RE-6)	33.7%
Total Percentage Reduction (RE-1)	50.2%

Affirmation Justification of the study

To affirm our study, we have to verify that our projections and calculations are correct. This is through model simulation of the new conditions on the 3D model generated on SketchUp on the IES-VE software. The software allows for the calculation and estimation of the energy efficiency of materials like solar panels. Therefore, allowing us to propose the use of tested and validated materials. The software generates

This was done by replacing the 3D model’s ACP walling material with aesthetic PV panels and calculating the panels' energy generation potential throughout the year. Putting in place some of the previously analyzed features like the sun path and radiance.

It is possible to derive a comparison or deviation in the results by comparing the model's IES VE annual energy generation analysis and our previously obtained calculations and projections.

(To be continued after the IES-VE analysis.)

5 Chapter 05

Results and Discussion

5.1 Overview

Because the Y tower Adnec building is located in Abu Dhabi, harnessing solar energy would be a great way to take advantage of the local environment and establish a sustainable energy building. The discussion below highlights the analysis results discussing the efficiency and functionality of the proposed ACP material. This is based on existing theory and research on sustainable construction materials. To results have been affirmed through modelling and simulation and a sun path analysis on the building.

5.2 Sun Path Analysis

A sun path analysis was necessary to analyse the efficiency and feasibility of the project, which involves adopting ACP to facilitate the harnessing of solar energy and the reduction of energy need in HVAC systems. From the Abu Dhabi and the Muskat regions analysis, the sun is usually visible for an estimated 13 hours per day but with shorter lengths during short days. The sun's path in Abu Dhabi covers all the directions but the Northside, which is not on the path, Figure 29.

The Y towers Adnec building is oriented so that the front façade faces the southeast, meaning that even the disadvantaged Northside receives its fair share of sunshine, especially during the early hours of the day.

5.3 Energy Saving Situation with Existing Building Material

Based on a calculation using Estidama standards, the existing building material (concrete blocks and DGU glass) has no potential of generating energy. This results in a renewable energy production rate (RE-6) of 0.0%. The Rockwool material has an energy-saving potential of 24.8%, resulting in an energy reduction rate (RE-1) of 24.8%.

5.4 Energy Efficiency

Substituting the material with aesthetic Aluminium Composite Panels, which have an energy production potential of 33.7%, will increase the building's total energy reduction rate by 50.2%. The 50.2% is the total sum of energy produced and energy savings from the used building material. Each panel used is expected to yield about 130 Watts per Square Meter. The total surface area fitted with the ACP material is 3150 square meters, which, when multiplied with the energy production potential per panel, results in a power production of 409.5 KiloWatts per Hour. With an average of 10 hours of sunshine per day, the building will generate 4095 kWh of electricity per day and 1494675 KWpH per year of green renewable solar energy.

5.5 Cost reduction

Assuming that the energy cost is; 25 Fils per kWh, the building, will be saving a total of 1494675 KWpH per year and a yearly cost savings of about 373668.8 AED. The savings increase considerably with the increase in the number of years that the systems are active.

5.6 Cost-Benefit vs. Investment

According to research and information obtained from production companies, the total energy saving cost from installing ACP material will be 373668.8 (AED). The total cost of installing the ACP panels is 1,512,00 AED. Diving the two gives us four years to acquire the money invested in setting up the ACP material from energy savings cost. This shows that the ACP material is not only cost-efficient but also contributes to sustainable energy reductions. After four years, the property owners will profit from energy production and the total energy needs reduction. The building will have 50.2% energy reductions owed to the production of 33.7% of renewable energy.

6 Conclusion

Although installing BIPV systems might require a high level of skill and knowledge and, most importantly, huge reserves to finance the costly projects, its long-term results, especially in reducing the amount of money spent on electric bills. Building materials also play a major role in making a building more energy efficient by reducing the energy required for HVAC systems.

The adoption of such innovative ideas also contributes to the optimization and sustainable use of available natural resources like wind energy and, in our case, solar energy. The ability to do this without negatively impacting the environment draws us a step closer to attaining sustainability. Matters related to sustainability, environmentally friendly materials, and green energy sources lead to reducing carbon emissions.

More emphasis needs to be put on the research, innovation, and development of policies like the Estidama Pearl building standards in Abu Dhabi. More funds and human resources need to be channelled towards these to reduce the buildings' negative environmental impacts. It is important to note that the changes and emphasis on the development and successful installation of energy-efficient and green building materials will only be achieved if the various bodies involved come together and collaborate on such projects.

Bibliography

Al-Ayish, N. 2017. Environmental Impact of Concrete Structures – with Focus on Durability and Resource Efficiency. pp. 1-41.

Amiri, A., Ottelin, J. & Sorvari, J., 2019. Are LEED-Certified Buildings Energy-Efficient in Practice?. *Sustainability*.

Amoruso, F. M. Dietrich, U. & Schuetze, T. 2019. Integrated BIM-parametric workflow-based analysis of daylight improvement for sustainable renovation of an ideal apartment in Seoul, Korea. *Sustainability (Switzerland)*, vol. 11 (9).

Attoye, D. E., Aoul, K. A. T. & Hassan, A., 2017. A review on building integrated photovoltaic façade customization potentials. *Sustainability (Switzerland)*, 9(12).

Attoye, D. E. et al. 2018. A conceptual framework for a Building Integrated Photovoltaics (BIPV) Educative-communication approach. *Sustainability (Switzerland)*, vol. 10 (10), pp. 1-21.

Ben Ghida, D., 2019. Heat recovery ventilation for energy-efficient buildings: Design, operation, and maintenance. *International Journal of Innovative Technology and Exploring Engineering*, 9(1), pp. 3713-3715.

Benestad, R. (2005). Climate change scenarios for northern Europe from multi-model IPCC AR4 climate simulations. *Geophysical Research Letters*, vol. 32 (17).

David Tan, A. K. S., 2011. Handbook for Solar Photovoltaic Systems. *Energy Market Authority, Singapore publication*.

Diaz, P. (2016). Analysis of Benefits, Advantages, and Challenges of Building Information Modelling in Construction Industry. *Journal of Advances in Civil Engineering*, vol. 2 (2), pp. 1-11.

Eoreports.wixsite.com, 2021. *Eoreports.wixsite.com*. [Online] Available at: <https://eoreports.wixsite.com/nanosolars/amsi> [Consultato il giorno 5 June 2021].

GOMAA, A. M., 2017. Implementation of Sustainability and Green Building Standards in the UAE: An analysis of Relevant Instruments.

Government of Dubai, 2012. Green Building Regulations & Specifications. pp. 1-75.

Gregory, R., Leiserowitz, A. & Failing, L. (2006). Climate Change Impacts, Vulnerabilities, and Adaptation in Northwest Alaska. *SSRN Electronic Journal*.

Guida, D. M. B. 2019. Heat Recovery Ventilation for Energy-Efficient Buildings: Design, Operation, and Maintenance. *International Journal of Innovative Technology and Exploring Engineering*, vol. 9 (1), pp. 3713-3715.

Hamilton, B. A., 2015. Green Building Economic Impact Study.

Hart, C., 1998. Doing a Literature Review. *Realising the Social Science of Research Imagination*, pp. 1-25.

"Heat Recovery Ventilation for Energy-Efficient Buildings: Design, Operation, and Maintenance." (2019).

Heinstein, P. & Ballif, C. P.-A. L. E., 2013. Building-integrated photovoltaics (BIPV): Review, potentials, barriers, and myths. *Green*, 3(2).

International Energy Agency, 2019. *BIPV Design and Performance Modelling: Tools and Methods*, s.l.: Report IEA-PVPS T15-09:2019.

Issa, N. & Al Abbar, S., 2015. Sustainability in the Middle East: achievements and challenges. *International Journal of Sustainable Building Technology and Urban Development*.

Jakica, N., Kragh, M. K., Yang, R. J. & W.M.Pabasara. 2019. *BIPV Design and Performance Modelling: Tools and Methods*, s.l.: s.n.

Jin, R., Zhong, B., Ma, L. & Hashemi, A. 2019. Integrating BIM with building performance analysis in project life-cycle. *Automation in Construction*.

Kayali, H. & Alibaba, D. H., 2017. Comparison of Different Solar Thermal Energy Collectors and Their Integration Possibilities in Architecture. *Sustainability in Environment*, 2(1), p. 36.

Khondaker, A. N. et al., 2016. Greenhouse gas emissions from the energy sector in the United Arab Emirates – An overview. *Renewable and Sustainable Energy Reviews*, Volume 59.

Li, J. et al. 2014. Benefits of Building Information Modelling in the Project Lifecycle: Construction Projects in Asia. *International Journal of Advanced Robotic Systems*, vol. 11 (8), p. 124.

Lu, Y. et al., 2019. Definition and Design of Zero Energy Buildings. *Green Energy Advances*.

Manandhar, P. et al. 2020. A study of local climate zones in Abu Dhabi with Urban weather stations and numerical simulations. *Sustainability*, vol. 12 (1), p. 15.

Ministry of Energy and Industry, 2017. *UAE National Energy Strategy 2050*, s.l.: s.n.

Mohammad, E. & Madani, A., 2012. *Greening Existing Buildings in the United Arab Emirates*, s.l.: s.n.

- Mohanty, P. et al., 2016. PV system design for off-grid applications. *Green Energy and Technology*, 196(May), pp. 49-83.
- Munari Probst, M. & Roecker, C., 2012. Extract from: Report T.41.A.2: IEA SHC Task 41 Solar energy and Architecture. SOLAR ENERGY SYSTEMS IN ARCHITECTURE integration criteria and guidelines.
- Nath Shukla, P. & Khare, A., 2014. Solar Photovoltaic Energy: The State-of-Art. *International Journal of Electrical, Electronics and Computer Engineering*, 3(2).
- Neshat, N., Amin-Naseri, M. R. & Danesh, F., 2014. Energy models: Methods and characteristics. *Journal of Energy in Southern Africa*, 25(4), pp. 101-111.
- NSAI, 2017. ISO 6946 The National Standards Authority of Ireland (NSAI) produces the following categories of formal documents.
- Osseweijer, F. J., van den Hurk, L. B., Teunissen, E. J. & van Sark, W. G., 2018. A comparative review of building-integrated photovoltaics ecosystems in selected European countries. *Renewable and Sustainable Energy Reviews*, Volume 90, pp. 1027-1040.
- Ramani, A. & García De Soto, B., 2021. Estidama and the pearl rating system: A comprehensive review and alignment with LCA. *Sustainability*.
- Ruiz, R. & Bandera, F., 2014. Importance of orientation in building energy savings. *World Sustainable Building Conference 14 Barcelona*, pp. 327-334.
- Sagheb, A., Vafaeihosseini, E. & Kumar, R. P., 2011. The Role of Building Construction Materials on Global Warming. *National Conference on Recent Trends in Civil and Mechanical Engineering*.
- Salama, M. & Hana, A. R. 2010. Green buildings and sustainable construction in the United Arab Emirates. *Association of Researchers in Construction Management, ARCOM 2010 - Proceedings of the 26th Annual Conference*, Issue September, pp. 1397-1405.
- Saupan, M. 2008. BIM + Sustainability: Case Study on IES VE Building Performance Simulation BIM + Sustainability: Case Study on IES VE Building Performance Simulation.
- Schropp, R., Beaucarne, G. & Carius, R., 2007. Amorphous Silicon, Microcrystalline Silicon, and Thin-Film Polycrystalline Silicon Solar Cells. *MRS Bulletin*, 32(3).
- Sreedevi, J., Ashwin, N. & Naini Raju, M., 2017. A study on grid-connected PV systems. *2016 National Power Systems Conference, NPSC 2016*.
- Tang, H.-h. & Hsiao, E. 2013. The advantages and disadvantages of multidisciplinary collaboration in design education. *Iasdr 2013*, pp. 2141-2150.

- Tang, G., 2010. *Masdar-The Sustainable Desert City: A Theoretical Mirage or A Realistic Possibility?* Amman, Jordan: s.n.
- Torcellini, P., Pless, S. & Crawley, D., 2006. Zero Energy Buildings: A Critical Look at the Definition; Preprint.
- U.S. Department of Energy, 2015. Zero Energy Buildings: What are they, and how do we build them?.
- Umar, U. A., Tukur, H., Khamidi, M. F. & Alkali, A. U., 2013. Impact of environmental assessment of green building materials on sustainable rating system. *Advanced Materials Research*, Volume 689, pp. 398-402.
- UNEP, 2009. Buildings and Climate Change. *Sustainable Buildings and Climate Initiative*.
- UNEP, 2018. Energy Efficiency for Buildings. *Energy For Sustainability*, Volume 33, pp. 173-213.
- USGBC, 2005. Buildings Account for 39% of CO 2 emissions in the United States.
- Wigley, T. M., Jones, P. D. & Kelly, P. M., 1981. *Global warming?*, s.l.: IPCC.
- Wolfe, C. B., Conine, D., Seavey, A. & Wills, S., 2009. Design Techniques, Construction Practices Materials for Affordable Housing. *Green Building Guide*.

Indices

Pearl Building Rating System Energy Model Template

إستدامة
estidama

This section is intended for the Project Energy Modelling Narrative. This brief narrative should provide an overview of the project and outline how compliance with the credit requirements is achieved. Content should include, but is not limited to, the following:

- a brief overview of the modelling process;
- summary of expected occupancy & use;
- building envelope systems & performance;
- HVAC and electrical systems performance;
- details of any additional calculation methodologies noted in the Exceptional Method and Renewables tabs

As well as highlighting targeted compliance within RE-1: Improved Energy Performance & RE-6: Renewable Energy Credits (where applicable).

Energy Modelling Narrative

The proposed project is developed 4 basements + ground +16 floors residential building is located in Abu Dhabi The project is implementing green building technologies and techniques in design & construction under "ESTIDAMA 2 pearl rating system". Detailed energy modeling was carried out as per ASHRAE 90.1-2007, for calculating the energy savings in the building. All Energy Conservation Measures (ECM) were evaluated based on simple payback periods and on the basis of feasibility. It was then combined to make a single case i.e., the final proposed case building.

The most cost effective and highly recommended efficient measures are designed,

- Efficient Wall Construction assembly
- Efficient Roof Construction assembly
- High Performance Double Glazing
- Reduced Interior Lighting power Density
- District Cooling system

With these above ECM measures the proposed building can achieve 24.8% improvement in energy consumption over the ASHRAE 90.1-2007 budget building yielding 5 Points for Improved Energy Performance in "ESTIDAMA Ver. 1.0".

Attachment 1; Etidama Pearl energy model template.

Pearl Building Rating System
Energy Model Template



This summary provides a comparison of the relative performance of the Proposed Building compared to the Baseline for the different energy end use types. Comparison for compliance purposes is made between the Baseline Building Average performance and the Proposed Building performance inclusive of contributions from Renewables and Exceptional Methods.

	Baseline, 0° Rotation		Baseline, 90° Rotation		Baseline, 180° Rotation		Baseline, 270° Rotation		Baseline Building, Average Annual Energy Consumption, kWh		Proposed Building (excluding Exceptional Method & Renewables)		Exceptional Method Annual Energy Saving, kWh	Proposed Building Annual Energy Consumption, kWh (excluding Renewables)
	Annual Energy Consumption, kWh	Peak Demand, kW	Annual Energy Consumption, kWh	Peak Demand, kW	Annual Energy Consumption, kWh	Peak Demand, kW	Annual Energy Consumption, kWh	Peak Demand, kW	Annual Energy Consumption, kWh	Peak Demand, kW	Annual Energy Consumption, kWh	Peak Demand, kW		
Space Cooling	2,562,215.0	1,146.9	2,543,453.0	1,031.2	2,443,373.0	1,116.1	2,397,963.0	1,145.0	2,539,375.0	1,621,403.0	524.9	0.0	1,621,403.0	
Heat Rejection	0.0	0.0	0.0	0.0	0.0	0.0	0.0	0.0	0.0	0.0	0.0	0.0	0.0	
Space Heating	0.0	0.0	0.0	0.0	0.0	0.0	0.0	0.0	0.0	0.0	0.0	0.0	0.0	
Pumps	0.0	0.0	0.0	0.0	0.0	0.0	0.0	0.0	0.0	151,056.0	31.4	0.0	151,056.0	
Fans - Interior	40,293.0	111.4	400,471.0	105.8	396,946.0	108.5	411,586.0	112.5	402,945.3	322,370.0	68.3	0.0	322,370.0	
Fans - Car park	0.0	0.0	0.0	0.0	0.0	0.0	0.0	0.0	0.0	0.0	0.0	0.0	0.0	
Interior Lighting	1,529,925.0	419.2	1,529,925.0	419.2	1,529,925.0	419.2	1,529,925.0	419.1	1,529,925.0	910,370.0	246.9	0.0	910,370.0	
Exterior Lighting	21,321.0	5.0	21,321.0	5.0	23,323.0	5.0	23,323.0	5.0	21,321.0	21,321.0	5.0	0.0	21,321.0	
Service Water Heating	373,488.0	149.1	373,488.0	149.1	373,488.0	149.1	373,488.0	149.1	373,488.0	373,488.0	149.1	0.0	373,488.0	
Receptacle/Process Equipment	888,782.0	242.5	888,782.0	242.5	888,782.0	242.5	888,782.0	242.5	888,782.0	888,782.0	242.5	0.0	888,782.0	
Data Centre Equipment	0.0	0.0	0.0	0.0	0.0	0.0	0.0	0.0	0.0	0.0	0.0	0.0	0.0	
Elevators and Escalators	146,000.0	40.0	146,000.0	40.0	146,000.0	40.0	146,000.0	40.0	146,000.0	146,000.0	40.0	0.0	146,000.0	
BASELINE TOTAL									5,903,449.3	Proposed Total (excluding Renewables)		4,437,892.0		
											Renewable Energy	0.0		
											PROPOSED TOTAL		4,437,892.0	
											PERCENTAGE IMPROVEMENT IN PROPOSED OVER BASELINE		24.8%	

ADNEC Y TOWER								
WEIGHTED AVERAGE WALL U-VALUE								
WALL TYPE	FRONT ELEV(M2)	RIGHT ELEV(M2)	REAR ELEV(M2)	LEFT ELEV(M2)	INTERNAL ELEV(M2)	TOTAL AREA (M2)	U-Value (W/m2k)	Area X U-Value (W/k)
WALL-01	80	153	256	70	0	559	0.500	279.5
WALL-02	25	628	25	184	252	1114	0.370	412.18
WALL-03	625	536	758	32	640	2591	0.310	803.21
WALL-04	102	119	95	313	84	713	0.550	392.15
WALL-05	85	54	27	0	0	166	1.930	320.38
WALL-06	25.1	101	14	0	14	154.1	0.340	52.394
WALL-07	67	0	0	0	0	67	0.350	23.45
WALL-08	99	168	144	23	0	434	0.500	217
TOTAL AREA	1108.1	1759	1319	622	990	5798.1		2500.264
Weighted Average U-Value w/m2k							0.431	
Design U-Value							0.44	
ALUMINUM & GLAZING Area (M2)	1478	1602	1130	2160	895	7265		
TOTAL CLADDING AREA (WALL 1 +2)	3150 sqm							

Attachment 3; Y- TowerAdnec Weighted average wall u-value calculations.

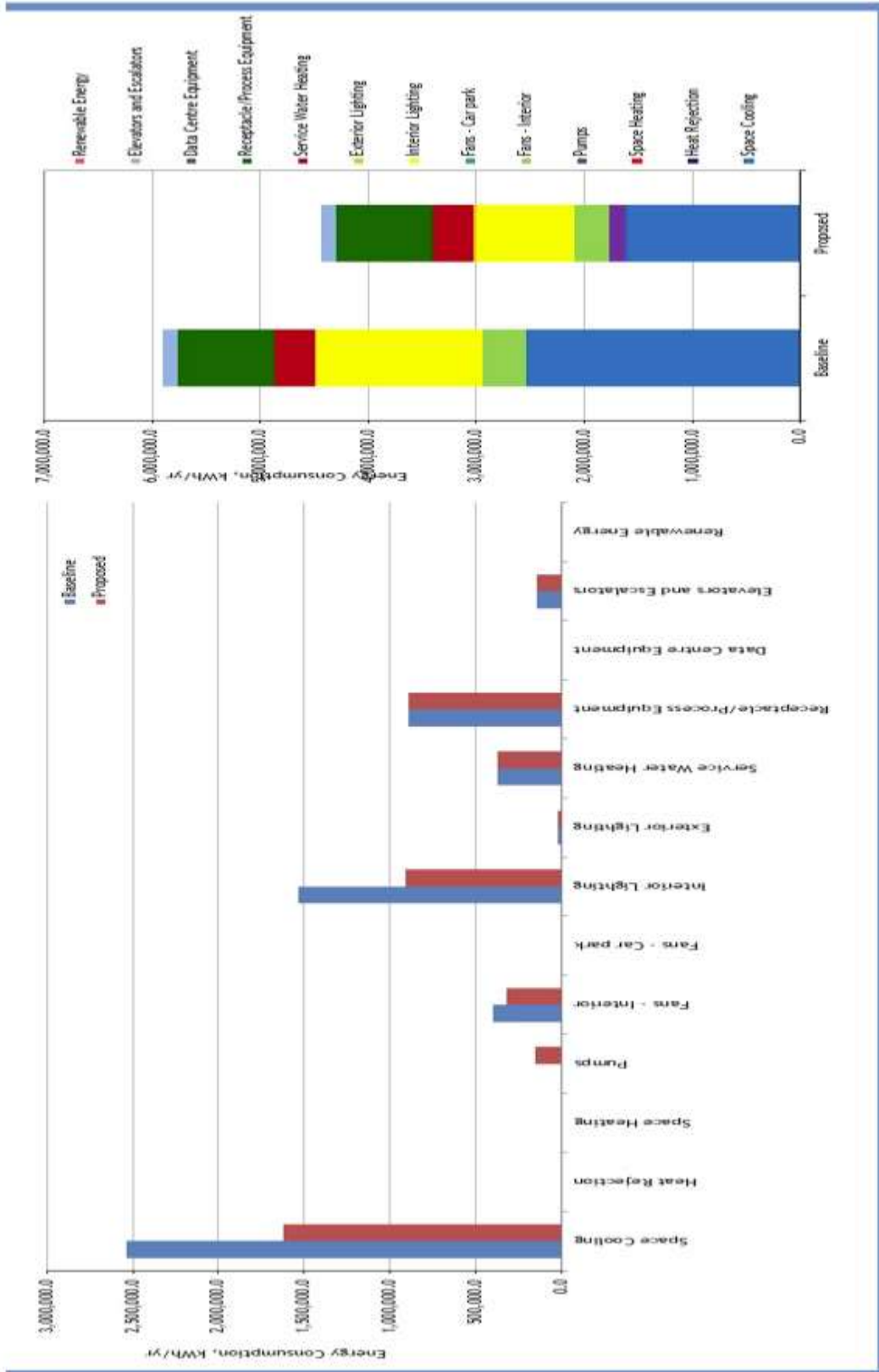

Attachment 4; Energy Consumption units for the Y-tower Adnec building.

Pearl Building Rating System Energy Model Template



This template has been developed to enable design teams to summarise model details and overall energy performance in order to demonstrate compliance with the mandatory provisions of RE-R1 and optional requirements of RE-1 and RE-6 in the Pearl Building Rating System. As outlined in the Pearl Building Rating System, energy performance analysis is based upon the Performance Rating Methodology outlined in ASHRAE 90.1-2007, Appendix G. This template must be populated by the Energy Modelling Specialist and verified by the Design Team MEP Engineer(s)

Input Cells that may be changed by design teams

Energy Model Summary	
Baseline Building Annual Energy Consumption, kWh	5,903,649.3
Baseline Building Annual Energy Consumption, Wh/m ²	116,072.4
Proposed Building Annual Energy Consumption, kWh	4,437,092.0
Proposed Building Annual Energy Consumption, Wh/m ²	87,238.2
Annual Renewable Energy Generation, kWh	0.0
Percentage of Energy from Renewables (RE-6)	0.0%
Total Percentage Reduction (RE-1)	24.8%

RE-R1: Minimum Energy Performance	
Pre-requisite Achieved?	Yes

RE-1: Improved Energy Performance	
Credit Points Awarded	5

RE-6: Renewable Energy	
Credit Points Awarded	0

Other Documentation Required:

Compliance summaries for ASHRAE 90.1-2007 from the Dynamic Simulation Modelling (DSM) software used.

If the software is not capable of producing these summaries, provide example input and output summaries for the baseline and proposed buildings.

The input summaries must include the following:

- the most common HVAC systems and their properties
- the most common lighting systems and their power densities and controls
- occupancy and usage patterns
- envelope element properties
- renewable energy systems and their properties (if present)

The output summaries must include the following:

- total building energy consumption
- energy consumption according to end use

The DSM software's standard input and output reports should be used, if these are not available provide screen shots instead.

Report a Template Bug: PBRS.EnergyModel@upc.gov.ae

Version 1.1

Pearl Building Rating System Energy Model Template



Building Fabric		
Item	Baseline Building	Proposed Building
Roof Construction	Insulation entirely above deck with U-Value of 0.357 W/m2.K	Reinforced concrete with polystyrene insulation with U-value of 0.30 W/m2.K
Above-Grade Wall Construction	Steel-Framed wall with U-Value of 0.704 W/m2.K	Concrete block with polystyrene insulation with U-value of 0.44 W/m2.K
Below-Grade Wall Construction		
Floor/Slab Construction	Steel-joise floor with U-Value of 1.98 W/m2.K	Reinforced concrete with U-value of 0.292 W/m2.K
Opaque Doors Construction	NA	NA
Vertical Glazing Ratio (gross window-to-wall)	25%	25%
Vertical Glazing Type and U-value, W/m ² .K (by orientation)	6.8 W/m2.K	1.35 W/m2.K
Vertical Glazing SHGC (by orientation)	0.25	0.17
Vertical Glazing Light Transmittance (by orientation)	40%	18%
Horizontal Glazing Ratio (gross skylight-to-roof)	NA	NA
Horizontal Type and U-value, W/m ² .K	NA	NA
Horizontal SHGC	NA	NA
Horizontal Light Transmittance	NA	NA
Shading Devices	None	None
Air Leakage Rate, l/s/m ² at 75Pa	3.64	3.64

Note: If the development is mixed-use and different construction types are required for different parts of the baseline building, enter all the construction types and the corresponding use. For example:

Roof Construction	Office: Insulation Entirely above Deck, U-0.360, R-2.6 c.i. Residential: Insulation Entirely above Deck, U-0.273, R-3.5 c.i.
-------------------	---

Attachment 7; Estidama Pearl Rating System- Energy Model Template describing the fabric of the base and remodelled building.

Wall U-value Calculator

Overview	Summary	Wall U-value	Floor U-value	Roof U-value	Glazing Spec	Materials	Glossary
----------	---------	--------------	---------------	--------------	--------------	-----------	----------

Entering the required information will enable calculation of the wall U-value. The Category and Material for each layer can be selected and the thickness varied to match the proposed design. Variations in material properties can be achieved via the materials tab, once they have been entered below. Any material not in the database should be entered as "Miscellaneous", "Other" and the Thermal Conductivity defined in the Materials tab. Full supporting documentation should also be provided.

Internal Design Temperature

Surface Finish

Category	Material	Layer Thickness (m)	Thermal Conductivity, k (W/m.K)	Thermal Resistance, R (m ² .K/W)
Cement/plaster/mortar	gypsum	0.012	0.420	0.029
Insulation	rock wool, 40kg/m3	0.100	0.038	2.632
Cement/plaster/mortar	gypsum	0.012	0.420	0.029

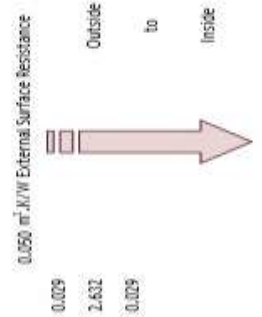

Light coloured surfaces help reduce heat gain through the fabric, particularly in hot Middle Eastern climates. Consider changing the Surface Finish.

Construction Thickness	0.124 m
Total Thermal Resistance	2.889 m ² .K/W
RE-R1 Target Average U-value	0.320 W/m ² .K
RE-2 Target Average U-value	0.290 W/m ² .K
Element Average U-value	0.346 W/m ² .K

Construction Fails RE-R1 U-value Target
Construction Fails RE-2 U-value Target

Previous

Home

Next

Wall U-value Calculator

Overview	Summary	Wall U-value	Floor U-value	Roof U-value	Glazing Spec	Materials	Glossary
----------	---------	--------------	---------------	--------------	--------------	-----------	----------

Entering the required information will enable calculation of the wall U-value. The Category and Material for each layer can be selected and the thickness varied to match the proposed design. Variations in material properties can be achieved via the materials tab, once they have been entered below. Any material not in the database should be entered as "Miscellaneous", "Other" and the Thermal Conductivity defined in the Materials tab. Full supporting documentation should also be provided.

Internal Design Temperature

Surface Finish

Category

Category	Material
Metals	aluminium cladding
Insulation	air gap
Insulation	rock wool, 60kg/m3
Concrete, cast	heavyweight, dry, 2000kg/m3

Layer Thickness
(m)

0.004	▶
0.026	▶
0.050	▶
0.400	▶

Thermal Conductivity, k
(W/m.K)

45.000
0.140
0.038
1.450

Thermal Resistance, R
(m².K/W)

0.000
0.186
1.316
0.276

0.050 m².K/W External Surface Resistance

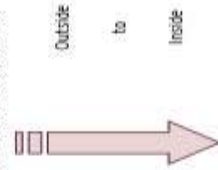

Light coloured surfaces help reduce heat gain through the fabric, particularly in hot Middle Eastern climates. Consider changing the Surface Finish.

0.150 m².K/W Internal Surface Resistance

Construction Thickness	0.480 m
Total Thermal Resistance	1.978 m ² .K/W
RE-R1 Target Average U-value	0.320 W/m ² .K
RE-2 Target Average U-value	0.290 W/m ² .K
Element Average U-value	0.506 W/m ² .K

Construction Fails RE-R1 U-value Target

Construction Fails RE-2 U-value Target

Previous

Home

Next

Material Properties

Overview	Summary	Wall U-value	Floor U-value	Roof U-value	Glazing Spec	Materials	Glossary
----------	---------	--------------	---------------	--------------	--------------	-----------	----------

Once materials have been selected for each of the elements their thermal properties can be edited by entering values in the highlighted cells below.

Should the performance entered exceed a certain range the value will be highlighted

Wall Elements		Roof Elements		Floor Elements				
Material	Thermal Conductivity, k		Material	Thermal Conductivity, k		Material	Thermal Conductivity, k	
	Typical	Proposed Revision		Typical	Proposed Revision		Typical	Proposed Revision
aluminium cladding	45.000							
air gap	1.060	0.140						
rock wool, 60kg/m3	0.033	0.038						
blocks, hollow, lightweight, 150 mm	0.480	1.134						
cement mortar	0.720							

Previous

Home

Next

Wall U-value Calculator

Overview	Summary	Wall U-value	Floor U-value	Roof U-value	Glazing Spec	Materials	Glossary
----------	---------	--------------	---------------	--------------	--------------	-----------	----------

Entering the required information will enable calculation of the wall U-value. The Category and Material for each layer can be selected and the thickness varied to match the proposed design. Variations in material properties can be achieved via the materials tab, once they have been entered below. Any material not in the database should be entered as "miscellaneous", "Other" and the Thermal Conductivity defined in the materials tab. Full supporting documentation should also be provided.

Internal Design Temperature

23

Surface Finish

White

Category	Material
Metals	aluminum cladding
Insulation	air gap
Insulation	rock wool, 60kg/m3
Concrete, cast	heavyweight, dry, 2000kg/m3
Cement/plaster/mortar	cement mortar

Layer Thickness (m)	Thermal Conductivity, k (W/m.K)	Thermal Resistance, R (m ² .K/W)	External Surface Resistance
0.004	45.000	0.000	0.050 m ² .K/W
0.026	0.140	0.186	Outside
0.050	0.038	1.316	to
0.150	1.450	0.103	Inside
0.015	0.720	0.021	

0.128 m².K/W Internal Surface Resistance

Construction Thickness	0.245 m
Total Thermal Resistance	1.804 m ² .K/W
RE-R1 Target Average U-value	0.320 W/m ² .K
RE-2 Target Average U-value	0.290 W/m ² .K
Element Average U-value	0.554 W/m ² .K

Construction Fails RE-R1 U-value Target
Construction Fails RE-2 U-value Target

Previous

Home

Next

Wall U-value Calculator

Overview	Summary	Wall U-value	Floor U-value	Roof U-value	Glazing Spec	Materials	Glossary
----------	---------	--------------	---------------	--------------	--------------	-----------	----------

Entering the required information will enable calculation of the wall U-value. The Category and Material for each layer can be selected and the thickness varied to match the proposed design. Variations in material properties can be achieved via the materials tab, once they have been entered below. Any material not in the database should be entered as "Miscellaneous", "Other" and the Thermal Conductivity defined in the Materials tab. Full supporting documentation should also be provided.

Internal Design Temperature

Surface Finish

Category	Material	Layer Thickness (m)	Thermal Conductivity, k (W/m.K)	Thermal Resistance, R (m ² .K/W)	External Surface Resistance	Internal Surface Resistance
Cement/plaster/mortar	cement mortar	0.015	0.720	0.021	0.050 m ² .K/W	
Concrete, cast	heavyweight, dry, 2000kg/m ³	0.400	1.450	0.276	Outside	
Cement/plaster/mortar	cement mortar	0.015	0.720	0.021	to	Inside
						0.150 m ² .K/W

Light coloured surfaces help reduce heat gain through the fabric, particularly in hot Middle Eastern climates. Consider changing the Surface Finish.

Construction Thickness	0.430 m
Total Thermal Resistance	0.518 m ² .K/W
RE-R1 Target Average U-value	0.320 W/m ² .K
RE-2 Target Average U-value	0.290 W/m ² .K
Element Average U-value	1.932 W/m ² .K

Construction Fails RE-R1 U-value Target
Construction Fails RE-2 U-value Target

Previous

Home

Next

Material Properties

Overview	Summary	Wall U-value	Floor U-value	Roof U-value	Glazing Spec	Materials	Glossary
----------	---------	--------------	---------------	--------------	--------------	-----------	----------

Once materials have been selected for each of the elements their thermal properties can be edited by entering values in the highlighted cells below.

Should the performance entered exceed a certain range the value will be highlighted

Wall Elements

Material	Thermal Conductivity, k	
	Typical	Proposed Revision
general	0.048	0.038
air gap	1.060	0.140
rock wool, 60kg/m3	0.033	0.038
heavyweight, dry, 2000kg/m3	1.300	1.450
cement mortar	0.720	

Roof Elements

Material	Thermal Conductivity, k	
	Typical	Proposed Revision

Floor Elements

Material	Thermal Conductivity, k	
	Typical	Proposed Revision

Previous

Home

Next